

# DOOR AWNING : GA SERIES

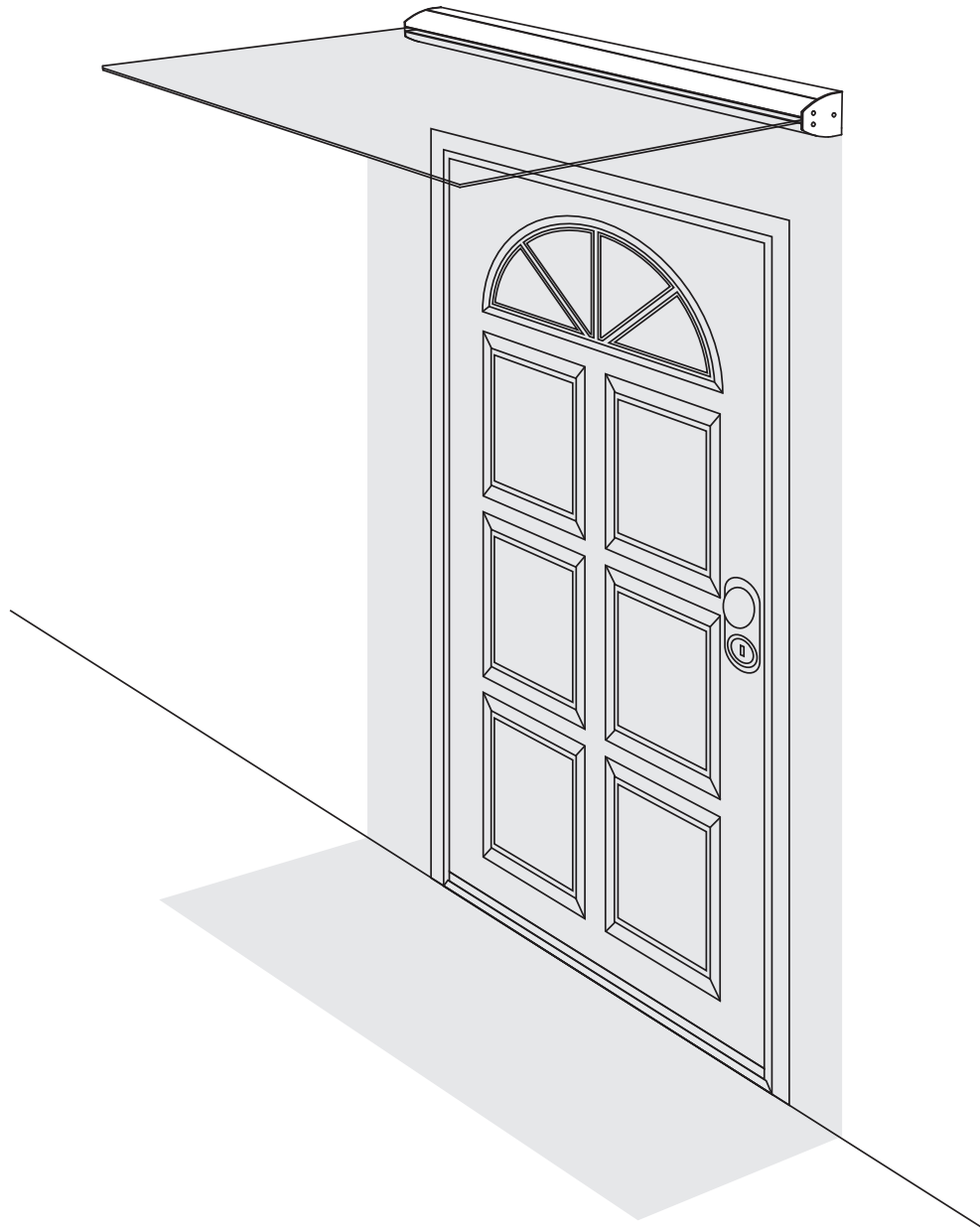

## Owner's Manual

For your safety and the safety of others, please read all of the instructions and warnings in this manual carefully before peceeding with installation and usage

# TABLE OF CONTENTS

Safety Instructions and Warnings .....	1~2
Package Contents and Parts .....	3
Assembly Diagram .....	4
Required Tools .....	5
Installation	
Pre-Installation Guide .....	6
Assembly and Installation .....	7~11
Maintenance .....	12
Limited Warranty and Contacts .....	13~14

## SAFETY INSTRUCTIONS AND WARNINGS

### CAUTION!

**GA Series awning MUST be mounted to main structural supports, header, or solid masonry 4-inch in thickness or more.**

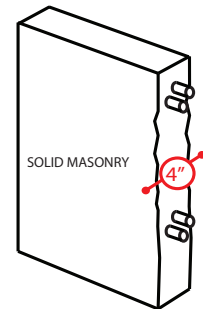
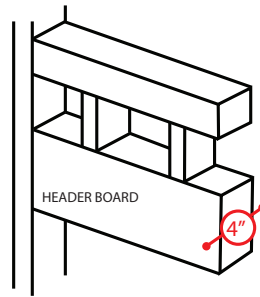

For your safety, ensure to have the following available:

- A. Minimum 3 people to install
- B. Work gloves
- C. Safety goggles

(A)

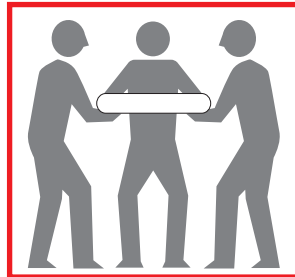

(B)

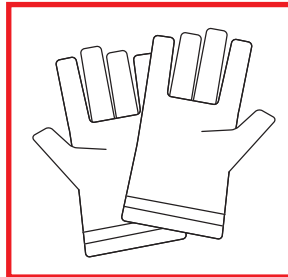

(C)

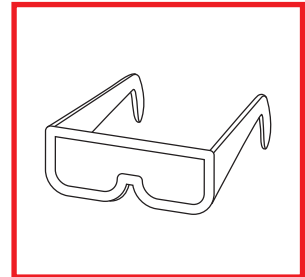
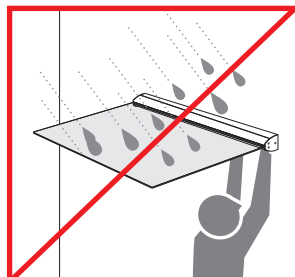

Fig.1

**DO NOT ATTEMPT Assembly or Maintenance if:**

- D. Rain is in the forecast
- E. Wind is in the forecast
- F. You are tired or under the influence of drugs or alcohol

(D)



(E)

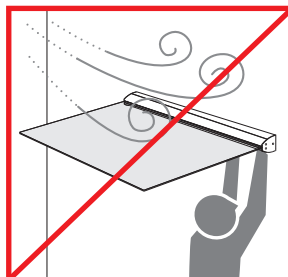

(F)



Fig.2

# SAFETY INSTRUCTIONS AND WARNINGS

**SAFETY FIRST, PLEASE READ THE FOLLOWING POINTS TO REDUCE THE RISK OF PERSONAL INJURY.**

Owners are solely responsible for proper handling, storage, assembly, installation and use of this product. Advaning is not responsible for any damages or injury to you, any other parties, or property resulting from improper handling, storage, assembly, installation, or misuse of the product.

## INSTALLATION

- Pay close attention throughout the installation process to ensure that the Advaning awning is installed properly and according to the safety guidelines outlined herein.
- Keep children away from the assembly area and components.
- Do not attempt installation while under the influence of alcohol or drug substances.
- Do not proceed with an installation if you feel that you cannot properly and safely complete, please seek professional help.
- Always wear protective gear and gloves when handling sharp metal parts.
- Only perform installation/maintenance/cleaning in dry and optimal weather conditions.
- 3 or more persons are recommended for installation. Installation will require to lift the glass panel onto the bracket. Ensure help is available to help lift and secure in position.
- Advaning recommends consulting with your local authorities if any permits or regulations are required prior to installation of this product.
- Ensure adequate installation substrate, GA Series awning **MUST** be mounted to main structural supports, header board, or solid masonry 4-inch in thickness or greater.

## USAGE

- Only use Advaning recommended accessories and original replacement parts.
- Only perform installation/maintenance/cleaning in dry and optimal weather conditions.
- Do not place any heat source or open flame under or near the awning.
- Do not place, hang, or stand objects or persons on the awning itself. Doing so can damage the awning or cause severe personal injury and in extreme cases death.
- Do not carry out any maintenance other than what is shown in this manual. For any issues that are not covered in this manual, please seek support from Advaning Customer Service. Email: [service@advaning.com](mailto:service@advaning.com)
- The product should be used only as described in this Advaning Owner's manual.



**ENSURE THAT THE DOOR AWNING IS MOUNTED TO MAIN STRUCTURAL SUPPORTS OF THE BUILDING. FAILURE TO DO SO MAY RESULT IN INJURY OR DAMAGE TO THE PRODUCT OR PROPERTY.**

# PACKAGE CONTENTS AND PARTS

Before installation, make certain that the package contains all parts as listed on this page.

- Ⓐ [Qty: 1] Tempered Glass Panel
- Ⓑ [Qty: 1] Awning Bracket (Base)
- Ⓒ [Qty: 1] Clear PVC Clip
- Ⓓ [Qty: 1] Awning Bracket (Top)
- Ⓔ [Qty: 1] Bracket Cover
- Ⓕ [Qty: 2] Rubber Strip
- Ⓖ [Qty: 6] Lag Screws & Washers
- Ⓗ [Qty: 8] Bracket Bolts
- Ⓘ [Qty: 2] Side Cover Foam
- Ⓝ [Qty: 2] Side Cover
- Ⓚ [Qty: 6] Side Cover Screws

Masonry Expansion Bolt,  
Part#: ZDA-WEB-R2  
NOT INCLUDED / SOLD  
SEPARATELY

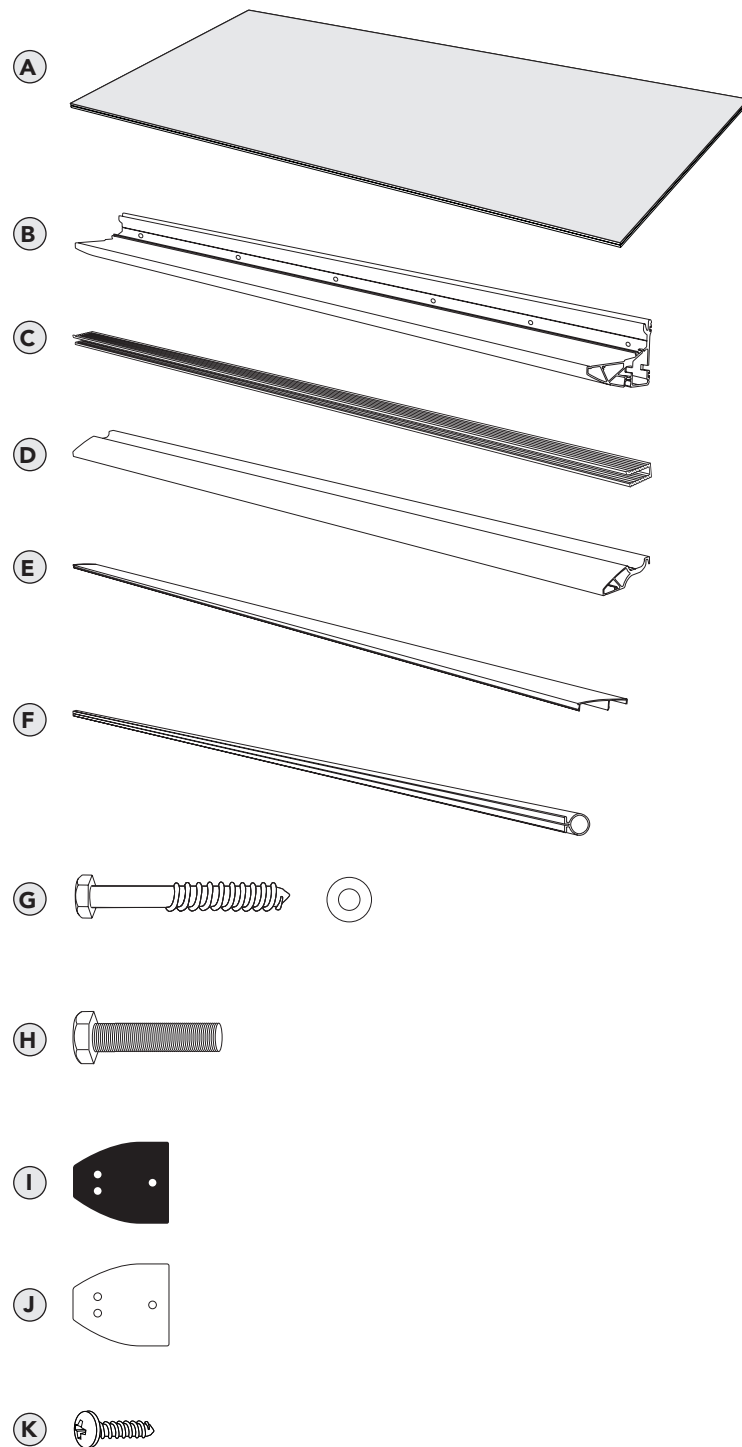

Fig 3

# ASSEMBLY DIAGRAM

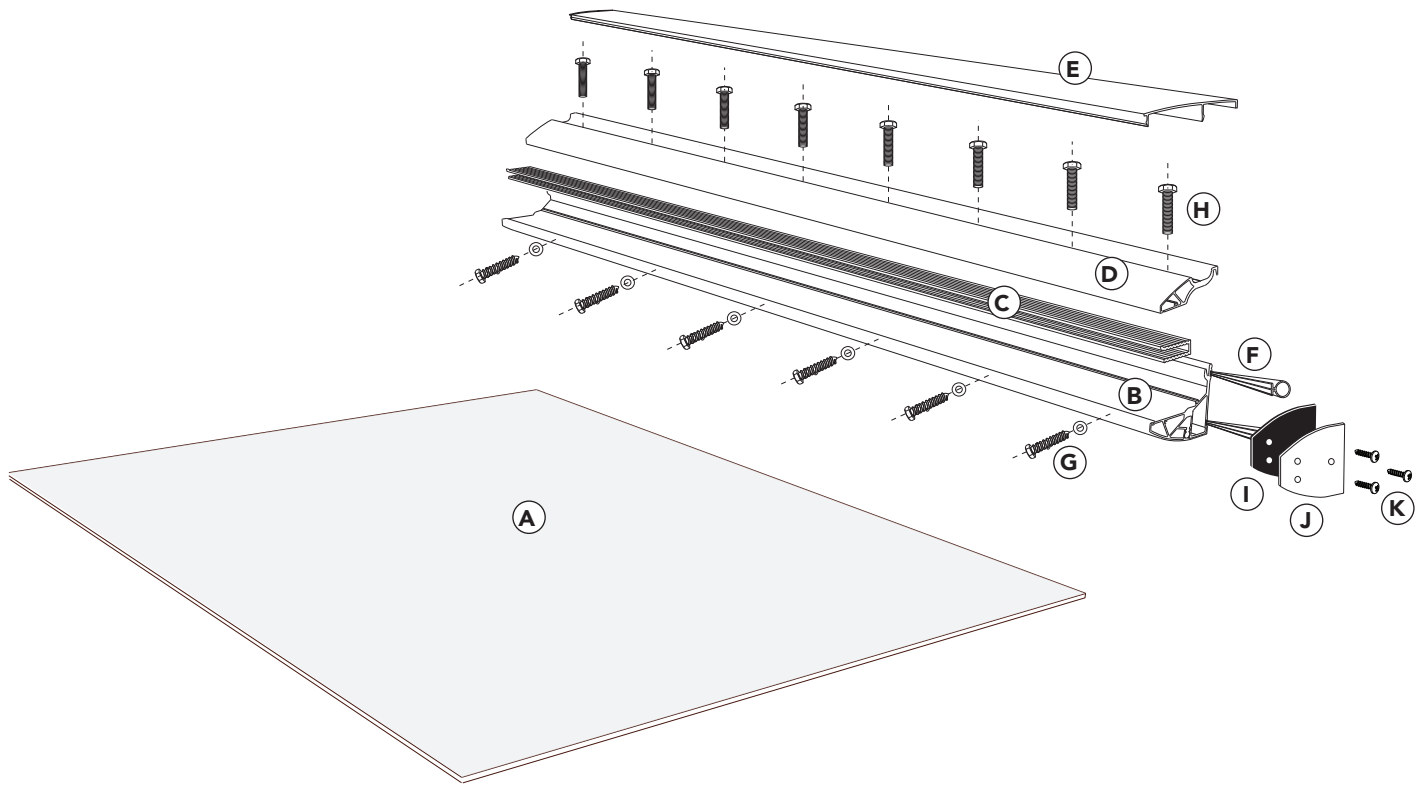
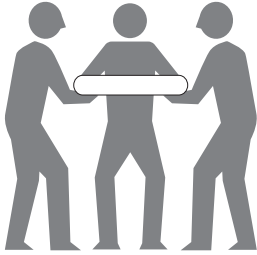

Fig.4

- Ⓐ Tempered Glass Panel
- Ⓑ Awning Bracket (Base)
- Ⓒ Clear PVC Clip
- Ⓓ Awning Bracket (Top)
- Ⓔ Bracket Cover
- Ⓕ Rubber Strip
- Ⓖ Lag Screws & Washers
- Ⓗ Bracket Bolts
- Ⓘ Side Cover Foam
- Ⓙ Side Cover
- Ⓚ Side Cover Screws

# REQUIRED TOOLS

Minimum 3 people to install.



## REQUIRED TOOLS

- ① Marker/Pencil
- ② Scissors
- ③ Level
- ④ 13mm Socket Wrench
- ⑤ Silicone\*
- ⑥ 9/64" Drill Bit for Lag Screw (wood installs).
- ⑦ Electric Drill
- ⑧ Phillips Head Screwdriver
- ⑨ Ladder/s
- ⑩ Work Gloves
- ⑪ Safety Glasses/Goggles

\*A slow curing high quality outdoor silicone is recommended – Specific for your exterior surfaces.

**NOTE:** For solid masonry installation a 3/8" drill bit will be required.  
Masonry Expansion Bolt,  
Part# ZDA-WEB-R2  
SOLD SEPARATELY

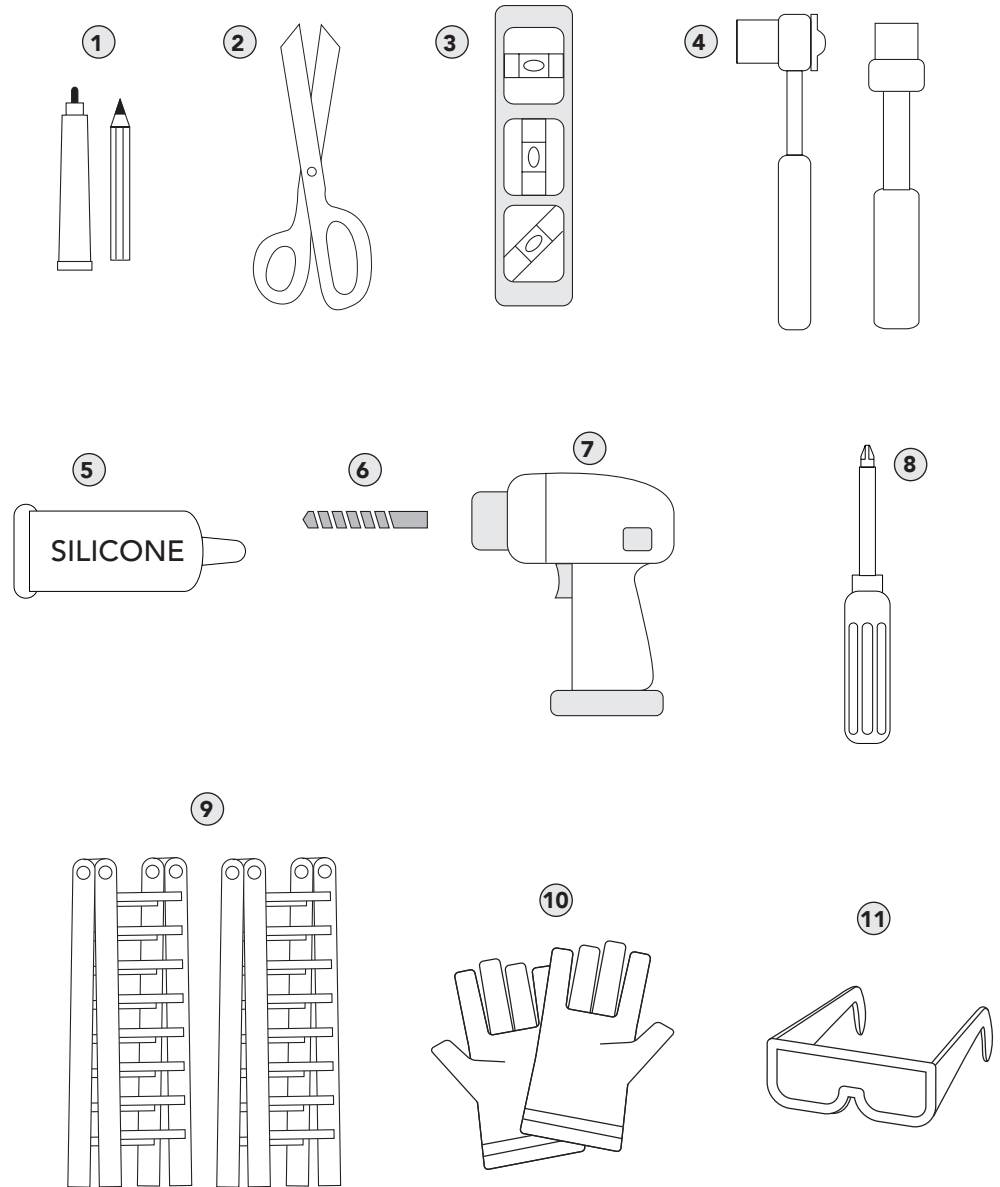

Fig.5

# PRE-INSTALLATION GUIDE

## PLANNING YOUR AWNING INSTALLATION

Locate your door/window structural header.

- (A) Minimum 2 inches of clearance below roof/eave/overhang.
- (B) 7 inches of clear vertical run length depending on awning size.
  - 55 or 63 inches
- (C) Minimum Depth Clearance depending on awning size.
  - 35 or 39 inches



Run length should be free & clear of any obstructions along the entirety of planned awning length.

Advaning highly recommends consulting with a professional installer/contractor who can best assess your specific installation challenges to avoid possible injury, property damage and ensure full product functionality.

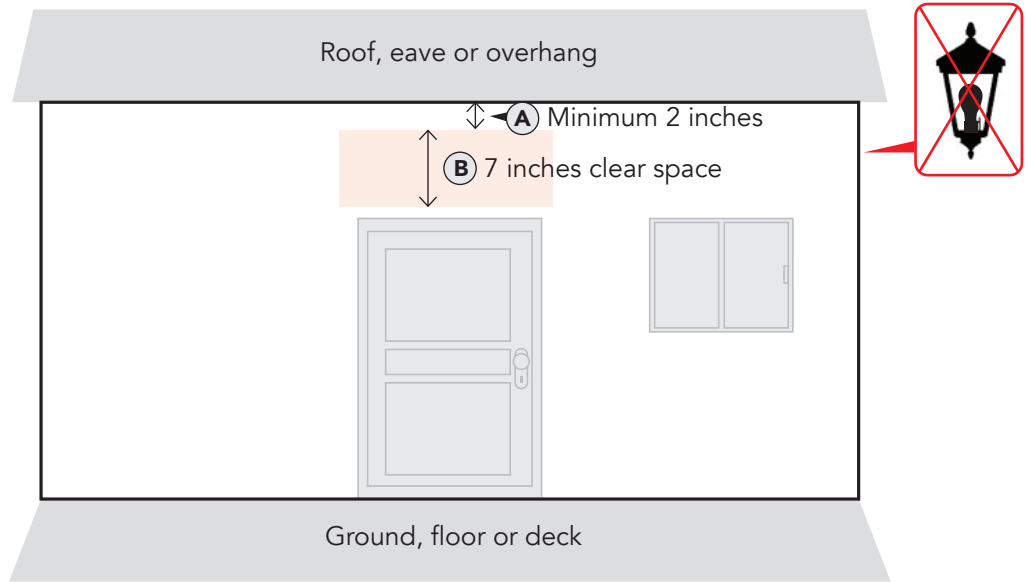
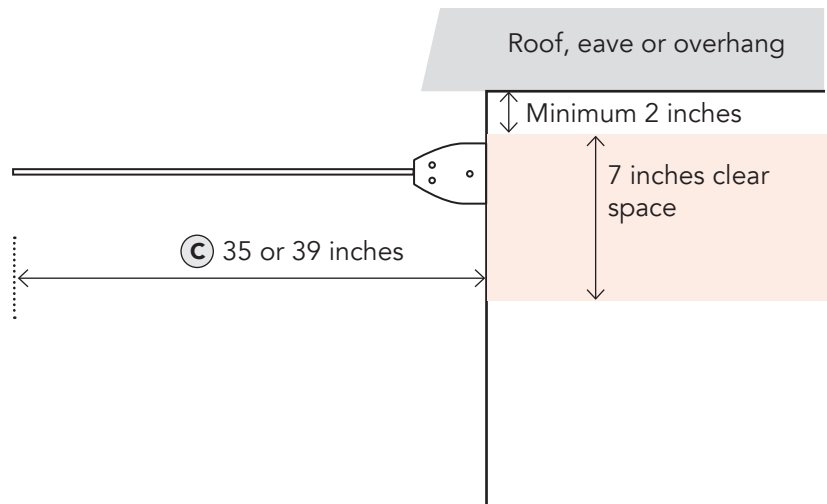

Fig 6 Personal & specific structural physicalities may require deviation from the recommended measurements.

### Side view

Fig 7



### CAUTION!

**GA Series awning MUST be mounted to main structural supports, header, or solid masonry 4-inch in thickness or more.**

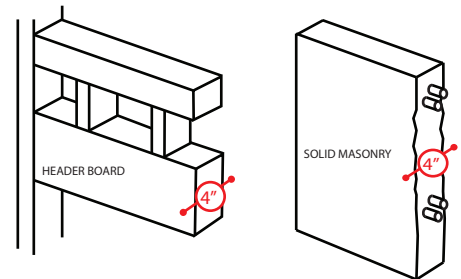

# ASSEMBLY AND INSTALLATION

## ASSEMBLING AND INSTALLING THE DOOR AWNING

**NOTE:** Installation instruction Step#5~8 is for wood installs only. For solid masonry installation guides, please visit [www.advaning.com](http://www.advaning.com) or request from Advaning's service team.

- ① Insert the Rubber Strips into the back grooves of the Awning Bracket (Base) and guide them through to the other end.
- ② Trim off excess Rubber Strips with scissors.
- ③ Using a level position the Awning Bracket (Base) in the desired install location.
- ④ Mark the location of the mounting holes using a marker/pencil through the bracket holes.
- ⑤ Remove the Awning Bracket (Base) and drill the pilot holes 4" deep.  
**TIP:** Drill the outer-most pilot holes first, then use the Awning Bracket (Base) as guide to drill the remaining holes.

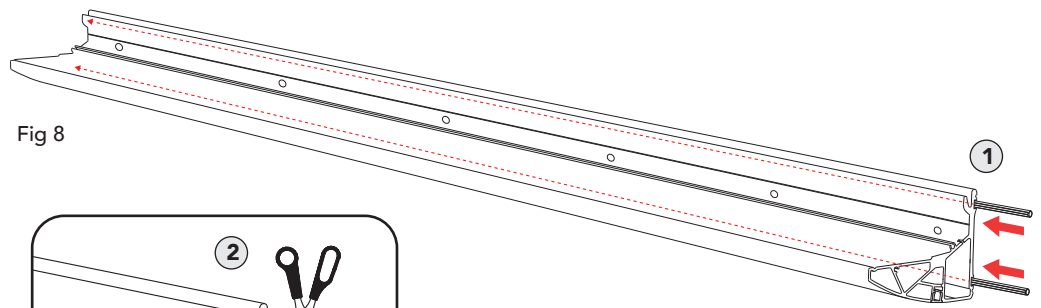

Fig 8

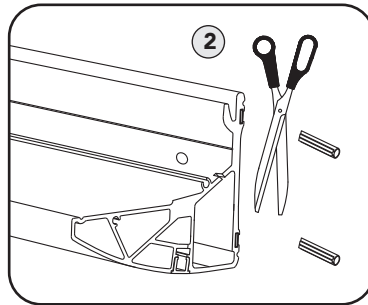

Fig 9

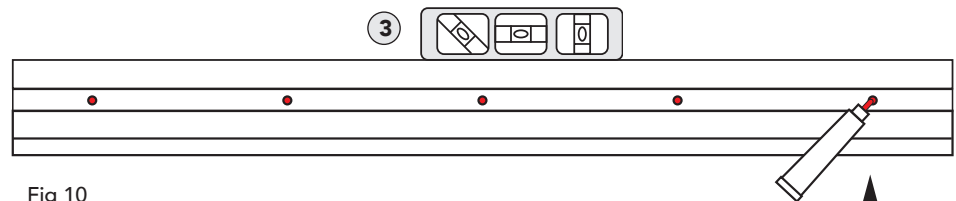

Fig 10

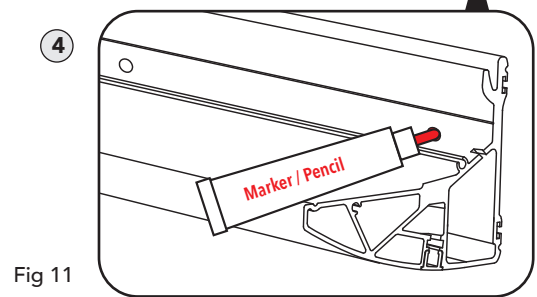

Fig 11

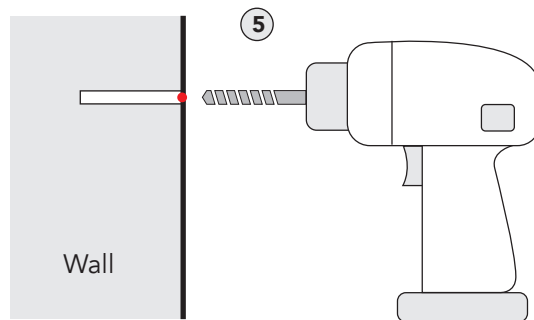
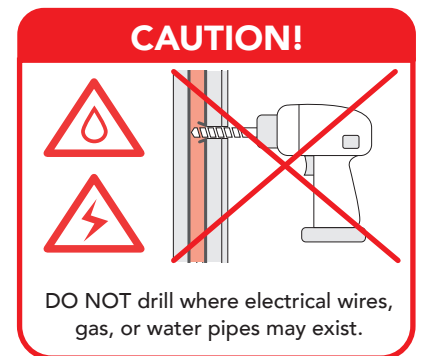

Fig 12





# ASSEMBLY AND INSTALLATION

- ⑥ Fill the mounting holes with silicone.

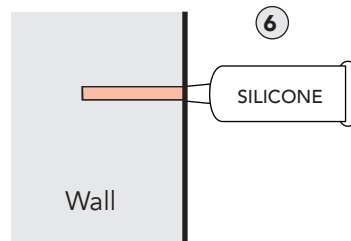

Fig 13

- ⑦ Align the Awning Bracket (Base) to pilot holes and insert the Lag Screws & Washers

**TIP:** Ensure the awning is level before proceeding with Step#8.

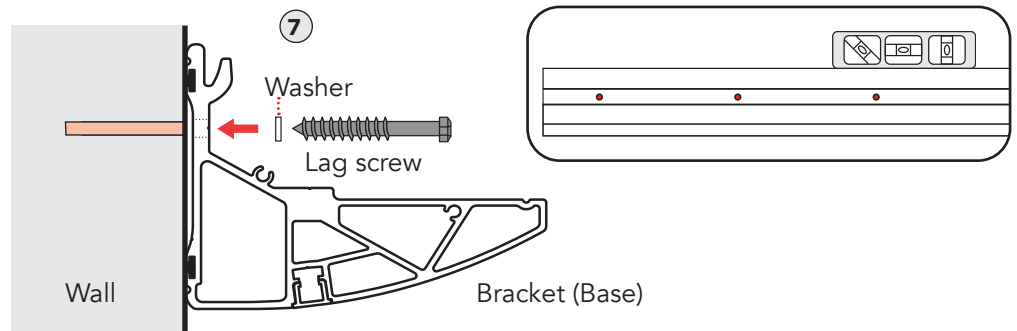

Fig 14

- ⑧ Securely tighten the Lag Screws with a 13mm socket wrench.

- ⑨ Prepare the Tempered Glass Panel placing the Clear PVC Clip over long edge.

**TIP:** The Tempered Glass Panel will arrive with a stretch wrap plastic – To avoid scratching the glass surface during installation, carefully cut the plastic wrap to allow the Clear PVC Clip to be attached and remove the remaining plastic wrap once entire awning is installed.

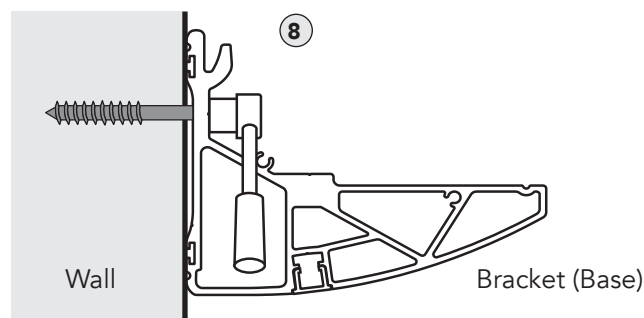

Fig 15

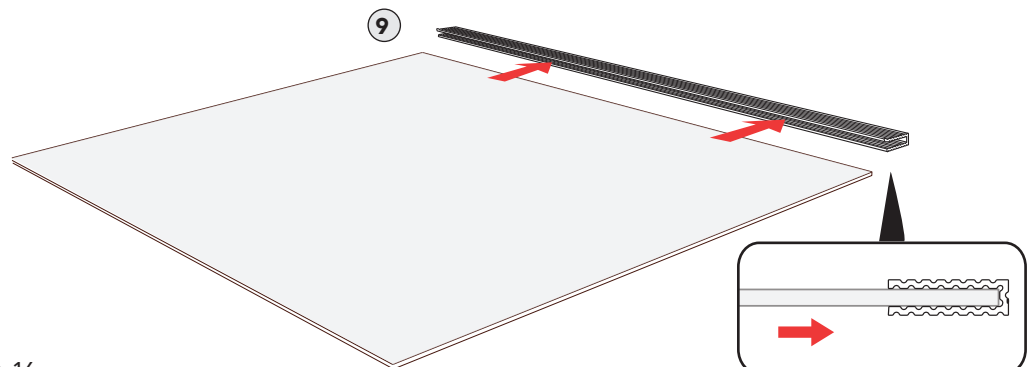

Fig 16

# ASSEMBLY AND INSTALLATION

**CAUTION:** Avoid damage and personal injury. Ensure there are at minimum two persons assisting with the handling of the Tempered Glass Panel while a third person secures the Awning Bracket (Top) assembly.

⑩ Place the Tempered Glass Panel with Clear PVC Clip on top of the Awning Bracket (Base) butting up to the internal bevel. See fig.19

⑪ Align the Awning Bracket (Top) with Awning Bracket (Base) bolt holes.

⑫ Insert the Bracket Bolts securing the Awning Bracket (Top) and the Tempered Glass Panel to Awning Bracket (Base).

**CAUTION:** Caution – DO NOT release support of the Tempered Glass Panel until all bolts are securely fastened, Step#13.

⑬ Securely tighten the Bracket Bolts with 13mm socket wrench.

**NOTE:** Ensure the Tempered Glass Panel with Clear PVC Clip is butting up to the internal bevel.

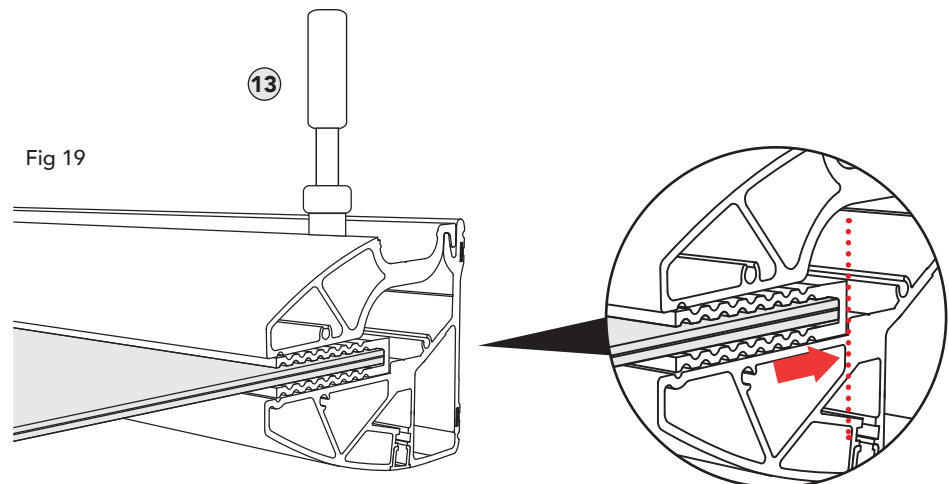
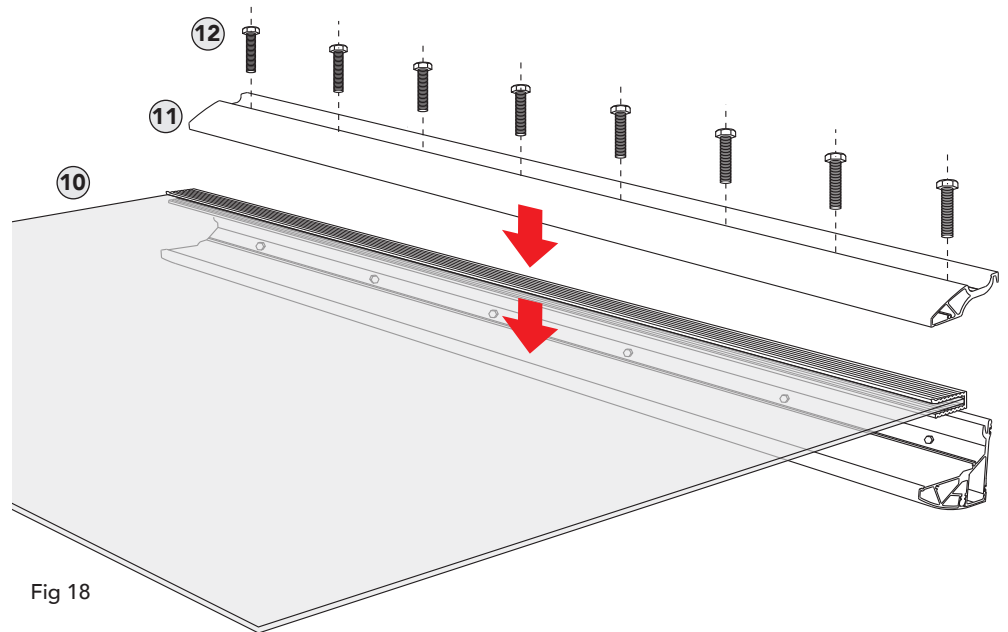
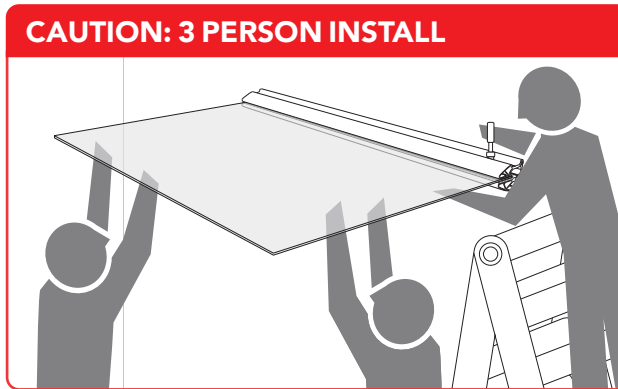

# ASSEMBLY AND INSTALLATION

⑭ Place the Bracket Cover over the Awning Bracket (Top) and clip it in place by applying a gentle force until secure.

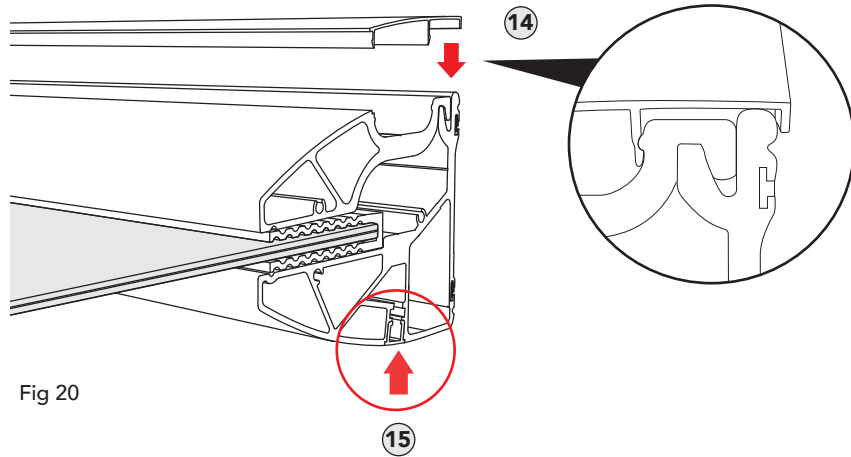

Fig 20

⑮ The Awning Bracket (Base) will include a white plastic strip base cover – Please check and secure in place if needed.

⑯ Prepare the Side Covers by first peeling the Side Cover Foam exposing the adhesive backing, aligning with Side Covers and firmly pressing together to affix.

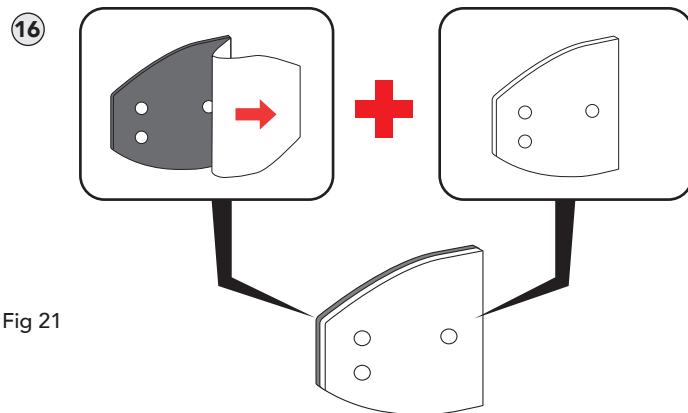

Fig 21

⑰ Align the Side Cover to the Awning Bracket assembly with the Side Cover Foam facing inward.

⑱ Secure the Side Covers with the Side Cover Screws using a Phillips Head screwdriver.

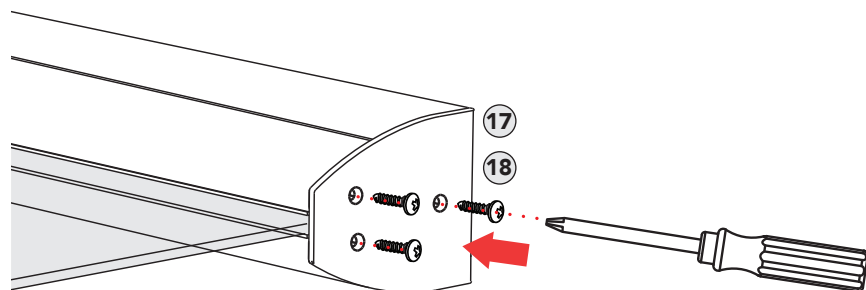

Fig 22

## ASSEMBLY AND INSTALLATION

- ①⑨ Apply the Silicone on the top of the Awning Bracket running along the wall for weatherproofing.

**NOTE:** Allow 24hrs for the silicone to fully set/cure.

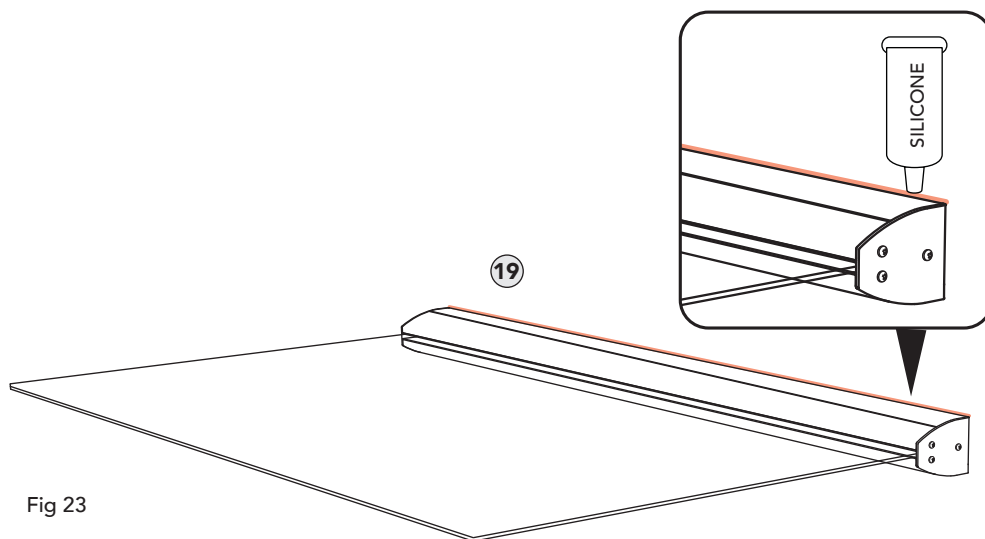

Fig 23

# MAINTENANCE

## CLEANING

To clean your GA Series awning, we recommend a 1 part (white vinegar) to 10 parts (water) cleaning solution mix. Use the cleaning solution in a spray bottle or dip into it with a sponge. Scrub off any dirt or debris with a sponge and wipe clean with lint free chamois cloth or squeegee. Prevent scratching the glass, only use soft cloth or rubber when cleaning your awning. Never use acetone, abrasives, detergents containing Hydrofluoric (HF) or Phosphoric acid (H3P04) or Bleach to clean your awning.

## CARE AND MAINTENANCE

Perform inspections (one to two times a year) to ensure that all the screws/bolts are properly tightened and that the silicone seals are in good condition. Re-tighten any and all screws/bolts and re-apply silicone as needed to prevent water leakage.

# LIMITED WARRANTY AND CONTACTS

## LIMITED WARRANTY COVERS

Advaning warrants all Advaning GA Series original products, sold and installed within the United States of America and Canada, to be free of defects in materials and workmanship. This warranty only applies to the original owner or purchaser of the product and is only effective on a basis for twelve (12) months or one (1) year from the date of purchase.

Any defects or issues presented to Advaning within the warranty period will be handled by Advaning Customer Service within a reasonable time.

The entire awning aluminum bracket, including the tempered glass panel and parts (page 3 of the Owner's Manual), is covered under the limited warranty.

Powder coated finishes and painted finishes are excluded and are NOT covered under this limited warranty.

During the warranty period, owners in Canada, Hawaii, Alaska, and Puerto Rico are covered for parts and replacements at no charge. However, the owner would assume all shipping and handling and applicable duties and taxes. Advaning's warranty does not cover any return shipping or prepaid return labels.

Should the original owner/purchaser submit a claim within the warranty period from the date of the purchase and after being deemed defective by Advaning, will the warranty claim be resolved by either of the following:

A. Defective components are replaced (shipping charges may apply).

and/or

B. Detailed correctional/resolving instructions will be provided.

## EXCLUSIONS AND LIMITATIONS OF WARRANTY

ANY MODIFICATIONS OR ALTERATIONS TO THE PRODUCT WILL VOID THIS WARRANTY.

ADVANING, INCLUDING ITS SUBSIDIARIES AND AFFILIATES, SHALL NOT BE RESPONSIBLE IN ANY MANNER WHATSOEVER FOR INJURY, DEATH OR DAMAGE TO PROPERTY AS A RESULT OF INTENTIONAL OR ACCIDENTAL MISUSED FOR PURPOSES FOR WHICH THE PRODUCT WAS NOT DESIGNED FOR.

The warranty will be in effect once the awning is fully paid for.

Advaning is not responsible for damage due to faulty modifications, installation, or re-installation. Advaning assumes no liability for damage to the structure to which the awning is attached, or to the property located underneath the awning. This limited warranty does not cover damage from ice, snow, hail, high winds, vandalism, neglect, improper use, or any natural disaster. This limited warranty does not cover degradation due to salt corrosion, oxidation, and chipping or peeling of the paint.

## What is Not Covered by the Advaning Limited Warranty

This warranty is non-transferable and does not cover product purchases from the initial buyer to a third party. This warranty does not cover incidental damages, such as loss of time, loss of use, or installation costs of defective, repaired, or replaced products. This warranty does not cover products that have been damaged or rendered defective as a result of:

# LIMITED WARRANTY AND CONTACTS

- (a) Neglect, abuse or misuse.
- (b) Modification of the original product.
- (c) Improper use or installation using products not manufactured by Advaning.
- (d) Service provided by anybody other than Advaning.
- (e) Abnormal mechanical or environmental conditions.
- (f) Unusual physical or electrical stress -including failure or fluctuation of electrical power, lighting, static electricity, fire, tornadoes, or other natural disasters.

## WARRANTY CLAIMS:

If you experience a problem with your Advaning product, please contact Advaning Customer Service representatives by email at [service@advaning.com](mailto:service@advaning.com), by phone at **714-622-2600** or by submitting a Warranty Claim via our website, [advaning.com/warranty-support](http://advaning.com/warranty-support)

Advaning Customer Service is available Monday through Friday from 8:30 a.m. to 4:00 p.m. PST

- Prior to contacting Advaning for warranty claims, please have your model name/number, \*original proof of purchase, photos and/or videos along with a description of the issue experiencing ready for our Customer Service team to assess.
- Submitting a claim will not extend or alter the warranty coverage period.
- Work performed by a third party or not authorized by an Advaning agent voids the warranty.

\*Original Proof of Purchase: A valid sales/purchase receipt is required with authorized reseller/retailer name, the purchase date, and the model number of the item purchased.

## SHIPPING DAMAGE/MISSING PARTS CLAIMS

On the occasion of a damage claim caused by the shipper/shipping company, the owner must contact their point of sale and the delivery carrier within 3-days of signing for the delivery in order to make a claim.

Likewise, there is a 7-day window from the time of delivery to report missing parts to Advaning.

Failure to report shipping damage and missing parts in a timely manner and in accordance with the shipper/ carrier guidelines may result in the owner incurring all costs.

THIS WARRANTY IS EXCLUSIVE AND IS IN LIEU OF ANY AND ALL OTHER WARRANTIES, EXPRESSED OR IMPLIED. NO IMPLIED WARRANTIES OF MERCHANTABILITY OR FITNESS FOR A PARTICULAR PURPOSE ARE GIVEN, ANY AND ALL LIABILITY FOR BREACH OF ANY IMPLIED WARRANTY OR WARRANTY CREATED BY LAW IS DISCLAIMED. Some states do not allow limitations on how long an implied warranty lasts, so the above limitation may not apply to you. UNDER NO CIRCUMSTANCES SHALL ADVANING, INCLUDING ITS SUBSIDIARIES AND AFFILIATES BE LIABLE FOR INCIDENTAL OR CONSEQUENTIAL DAMAGES WITH RESPECT TO ECONOMIC LOSS, INJURY, DEATH OR PROPERTY DAMAGE, WHETHER AS A RESULT OF BREACH OF THIS WARRANTY, NEGLIGENCE OR OTHERWISE. Some states do not allow the exclusion or limitation of incidental or consequential damages, so the above limitation or exclusion may not apply to you in whole or in part. This warranty gives you specific legal rights. You may also have other rights that vary from state to state.

## CONTACT INFORMATION

### Product Questions?

Please contact Advaning via email at [service@advaning.com](mailto:service@advaning.com), by phone at 714-622-2600, or by chat on our website; [www.advaning.com](http://www.advaning.com)

Advaning Customer Service is available Monday through Friday from 8:30 a.m. to 4:00 p.m. PST

[www.advaning.com](http://www.advaning.com)