

# PN SERIES : Polycarbonate Awning

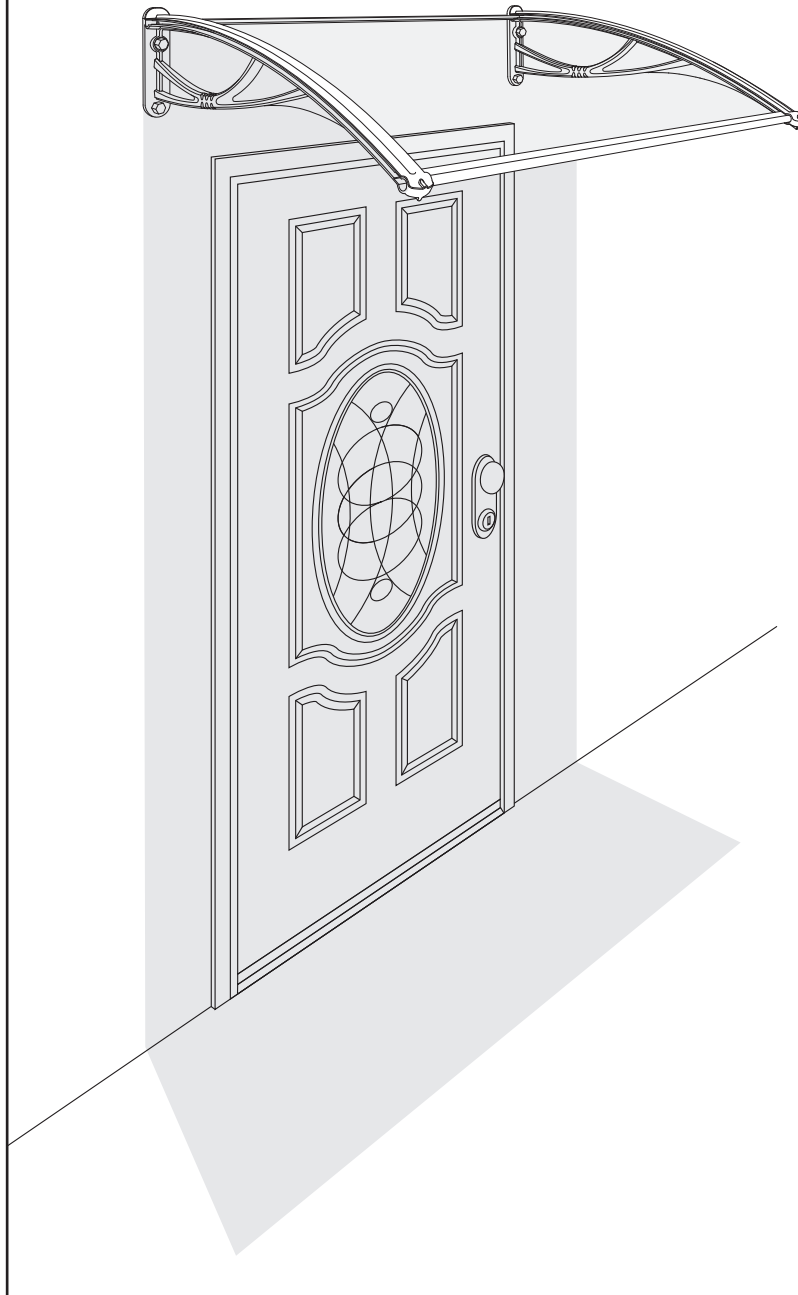

## Owner's Manual

For your safety and the safety of others, please read all of the instructions and warnings in this manual carefully before proceeding with assembly and usage.

# TABLE OF CONTENTS

Safety instructions and warnings .....	1~2
Package contents and parts .....	3
Tool requirements .....	4
Awning terminology.....	5
Pre-Installation guide.....	6
Awning assembly.....	7~10
Awning installation.....	11~13
Connecting multiple awnings .....	14
Maintenance and care .....	15
Warranty and service.....	16~17

## SAFETY INSTRUCTIONS AND WARNINGS

For your safety, we strongly recommend the following during assembly and installation:

- A: Minimum 2 people
- B: Work gloves
- C: Safety goggles

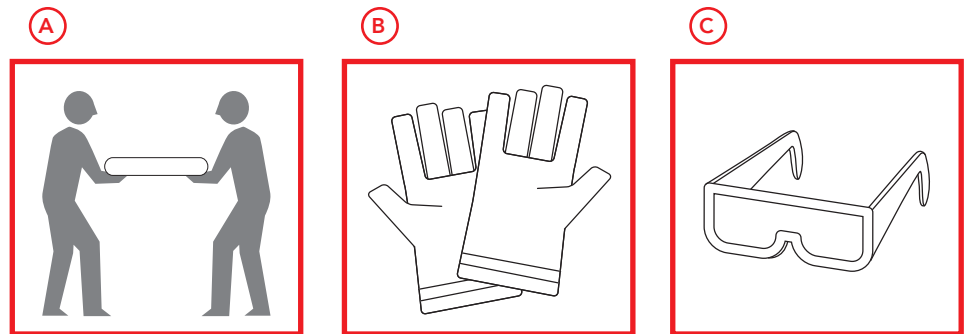

Fig.1

DO NOT ATTEMPT to assemble or install if:

- D: Rain is in the forecast
- E: Wind is in the forecast
- F: You are tired or under the influence of drugs, medication or alcohol

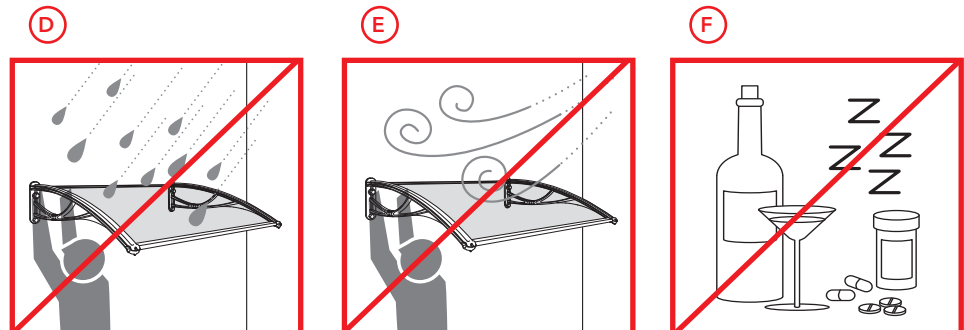

Fig.2

# SAFETY INSTRUCTIONS AND WARNINGS

## SAFETY FIRST, PLEASE READ THE FOLLOWING POINTS TO REDUCE THE RISK OF PERSONAL INJURY

Owners are solely responsible for the proper handling, storage, assembly, installation, and use of this product. Advaning is not responsible for any damages or injury to you, any other parties, or property resulting from improper handling, storage, assembly, installation, or misuse of the product.

- Consult with your local authorities if any permits are required prior to the installation of this product. This product is intended for residential use only. Do not use this product other than for its intended purpose.

### ASSEMBLY

- Please keep children away from the assembly area and from handling assembly components.
- Ensure that all screws are properly tightened when assembling the awning.
- Use caution with sharp metal edges by wearing protective gloves and safety goggles.
- Follow all 3rd party manufacturer's safety instructions when using mechanical power tools and ladders during assembly and installation.

### INSTALLATION

- Pay close attention throughout the installation process to ensure that the Advaning awning is installed properly and according to the safety guidelines outlined herein.
- Do not attempt installation while under the influence of alcohol or drug substances.
- Do not proceed with an installation if you feel that you cannot properly and safely complete it; please seek professional help.
- Two or more people are recommended for installation. Installation will require lifting the assembled awning. Ascertain that assistance is available to lift and secure in position.
- Make certain that the installation substrate is adequate (the PN Series awning **MUST** be mounted to the main structural supports) studs, header board, or solid masonry 3-inch in thickness or greater.
- Do not drill into walls where electric wiring, gas pipes, or water pipes may exist.

### USAGE









- Only use Advaning-recommended accessories and original replacement parts.
- Only perform installation, maintenance, and cleaning in dry and optimal weather conditions.
- Never put a heat source or an open flame under or near the awning.
- Do not place, hang, or stand objects or people on the awning itself. Doing so can damage the awning or cause severe personal injury and, in extreme cases, death.
- Do not carry out any maintenance other than what is shown in this manual. For any issues that are not covered in this manual, please seek support from Advaning Customer Service. Email: [service@advaning.com](mailto:service@advaning.com)
- The product should be used only as described within this owner's manual.

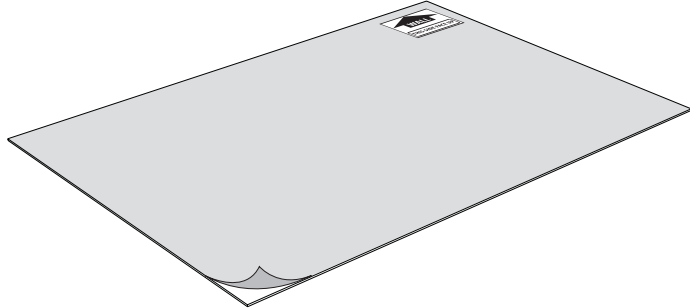
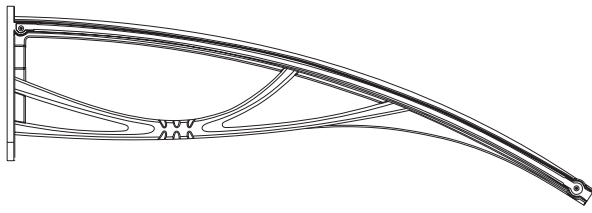

**CAUTION! AWNING MUST BE MOUNTED TO MAIN STRUCTURAL SUPPORTS OR SOLID MASONRY. FAILURE TO DO SO MAY RESULT IN PERSONAL INJURY, PRODUCT OR PROPERTY DAMAGE.**

# PACKAGE CONTENTS AND PARTS

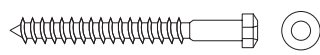
Before attempting your assembly, please ensure that the package contains all parts and qty's as listed on this page.

	Part		Quantity
A	Solid Polycarbonate Sheet		1
B	Fiberglass Reinforced Nylon Bracket		2
C	Aluminum Front Bar		1
D	Aluminum Back Bar		1
E	Long Rubber Strip Gasket (Front/Back)		2
F	Short Rubber Strip Gasket (Sides)		2
G	Wall Rubber Strip Gasket		1
H	Phillips Head Securing Screw		4
I	Lag Screw Set for Wood Installs (Lag & Washer)		4
J	Mounting Hardware Cap		4

Masonry Expansion Bolt, Part#: ZDA-WEB-R2 NOT INCLUDED / SOLD SEPARATELY

Fig.3

# TOOL REQUIREMENTS

## RECOMMENDATION

Minimum 2 people to install.

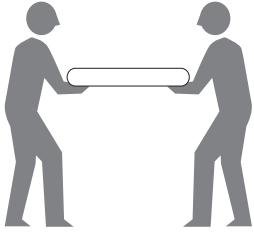

## SUGGESTED TOOLS

- ① Marker/Pencil
- ② Scissors
- ③ Rubber Mallet
- ④ Phillips Screwdriver
- ⑤ 1/2" Wrench or Socket Wrench
- ⑥ Level
- ⑦ Small Wood Block
- ⑧ Slow Curing Outdoor Silicone
- ⑨ 15/64" or 1/4" Drill Bit/s for Wood Installs
- ⑩ Drill
- ⑪ Ladder/s
- ⑫ OPTIONAL: Weather Stripping Adhesive

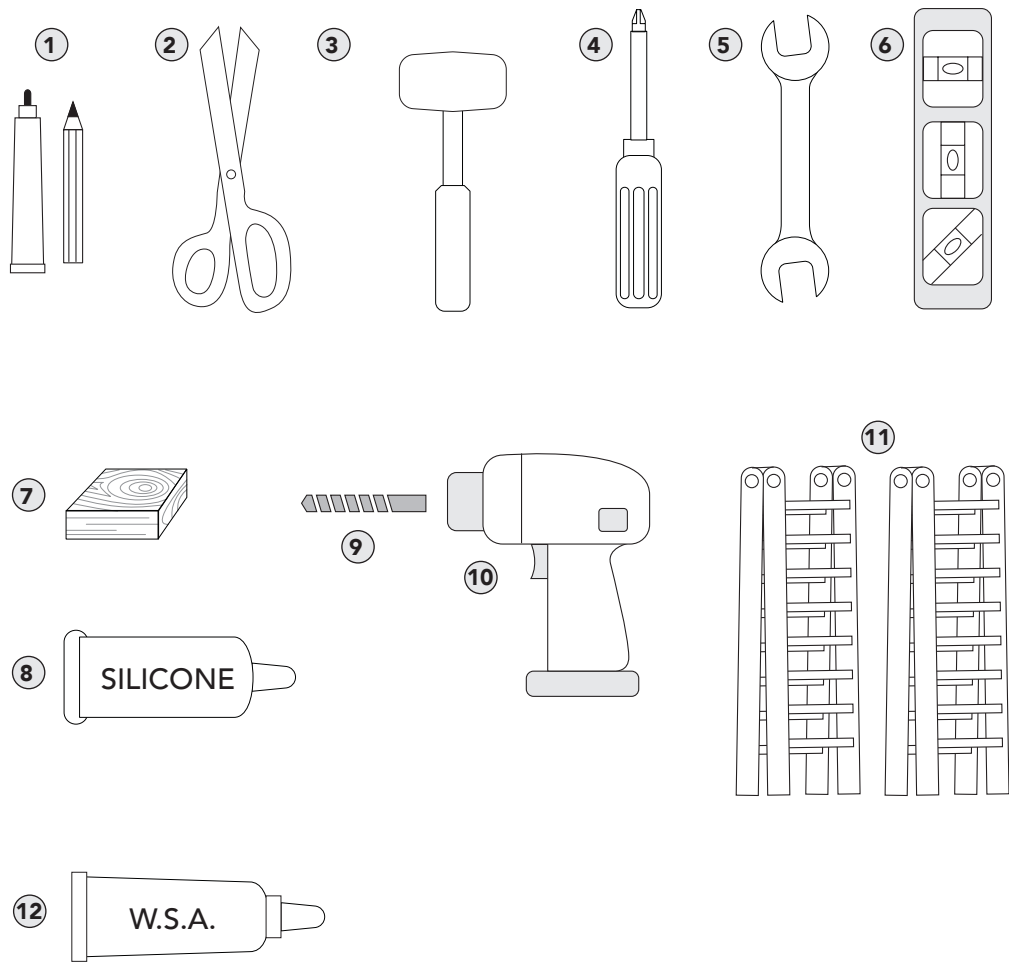

Fig.4

\*A ratchet tie down set for connecting multiple units (not pictured).

# AWNING TERMINOLOGY AND LOCATION

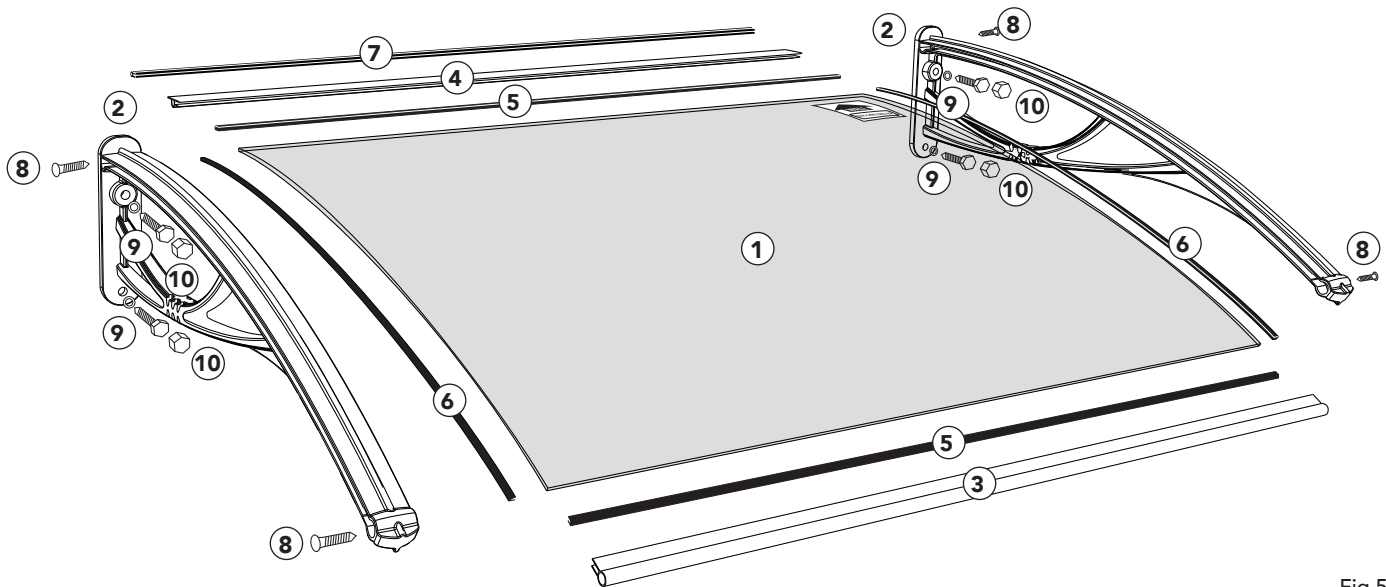

Fig.5

- ① Awning Polycarbonat Sheet
- ② Awning Bracket
- ③ Awning Front Bar
- ④ Awning Back Bar
- ⑤ Front/Back Long Rubber Gasket
- ⑥ Short Rubber Gasket
- ⑦ Wall Rubber Gasket
- ⑧ Bracket Securing Screw
- ⑨ Mounting Hardware (Lag or Expansion)
- ⑩ Mounting Hardware Cap

# PRE-INSTALLATION GUIDE

## PLANNING YOUR AWNING INSTALLATION

Locate your door/window structural header.

- Ⓐ Minimum 2 inches of clearance below roof/eave/overhang.
- Ⓑ 10 inches of clear vertical run length.
- Ⓒ Minimum Depth of 31 inches.



Run length should be free & clear of any obstructions along the entirety of planned awning length.

Advaning highly recommends consulting with a professional installer/contractor who can best assess your specific installation challenges to avoid possible injury, property damage and ensure full product functionality.

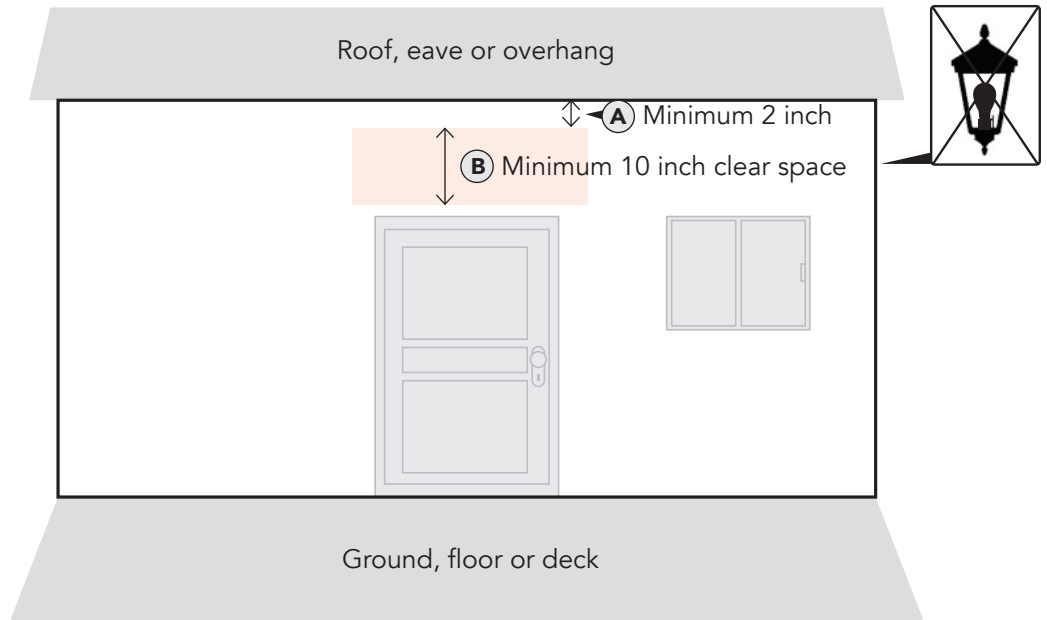

Fig 6

### Side view

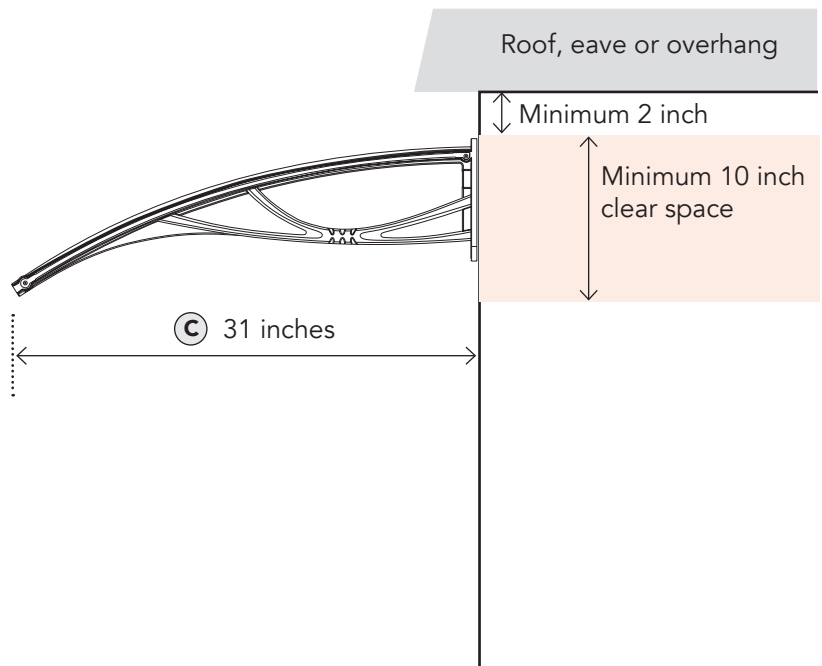

Fig 7

# AWNING ASSEMBLY

## PREPARING THE POLYCARBONATE SHEET

- ① Carefully peel the protective film approximately 2 inches from both the top and bottom on front and back edges of the sheet.
- ② Dry fit the gaskets to polycarbonate or (OPTIONAL) apply a small bead of Weather Stripping Adhesive (W.S.A.) to the gasket inner side before connecting.

Ensure to follow W.S.A. instructions & have a rag to wipe off any excess.

- ③ Ensure the Rubber Strip Gaskets are smoothly connected to the sheet and with scissors trim off the excess Rubber Strip Gasket.

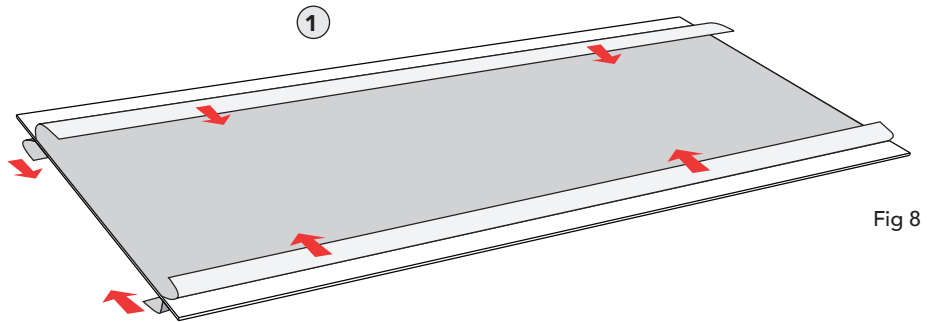

Fig 8

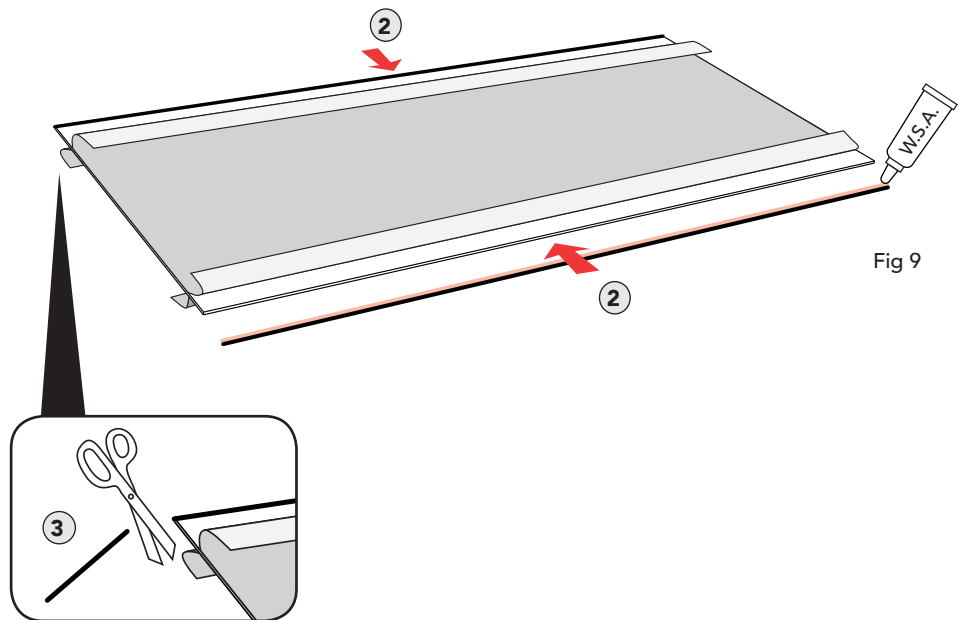

Fig 9



# AWNING ASSEMBLY

④ Join the Awning Front & Back Bars to sheet by pressing onto the Rubber Strip Gasket edges. Ensure the Awning Front & Back Bars are correctly oriented as illustrated in fig. 10 labeled THIS SIDE UP.

⑤ Using a small wooden block and rubber mallet, tap along the entire length of the Awning Front & Back Bars to firmly secure in place.

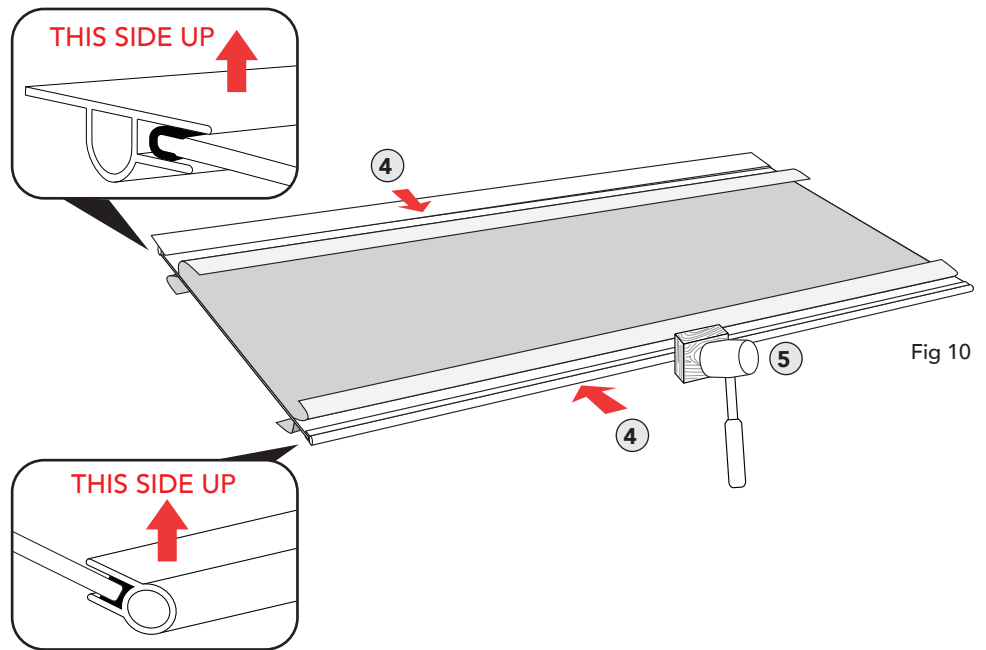

## ATTACHING THE BRACKETS

⑥ Carefully peel the protective film approximately 2 inches from both the top and bottom on both sides of the sheet.

⑦ Dry fit the gaskets to polycarbonate sides or (OPTIONAL) apply a small bead of Weather Stripping Adhesive (W.S.A) to the gasket inner side before connecting.

Ensure to follow W.S.A. instructions & have a rag to wipe off any excess.

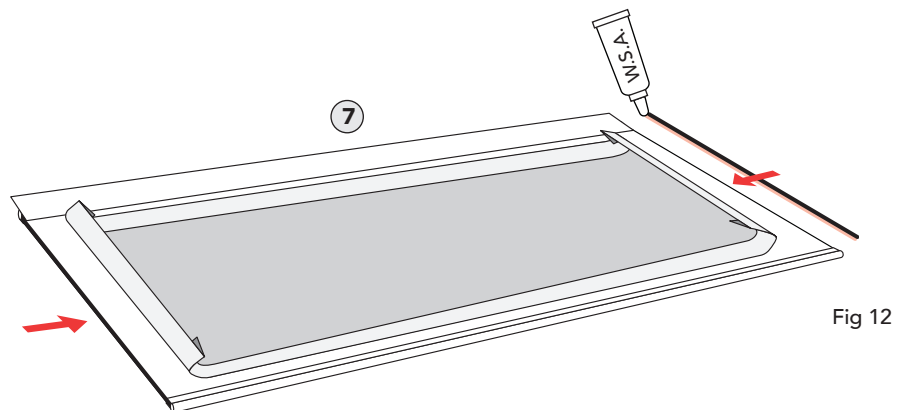
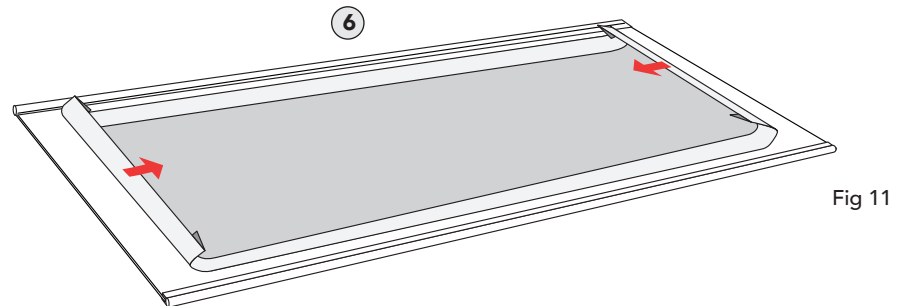

# AWNING ASSEMBLY

## ATTACHING THE BRACKETS

- ⑧ Join the Brackets to the Right and Left sides by firmly pressing the Rubber Strip Gasket edges one at a time to the Bracket inset groove.

Tip: Use a mallet to tap in place once the sheet is aligned within the bracket inset groove.

- ⑨ Using a Phillips Screwdriver, secure the brackets to the Front and Back Bars with the Securing Screws.

- ⑩ Dry fit the Wall Rubber Gasket to Back Bar or (OPTIONAL) apply a small bead of Weather Stripping Adhesive (W.S.A) to the gasket inner side before connecting.

Ensure to follow W.S.A. instructions & have a rag to wipe off any excess.

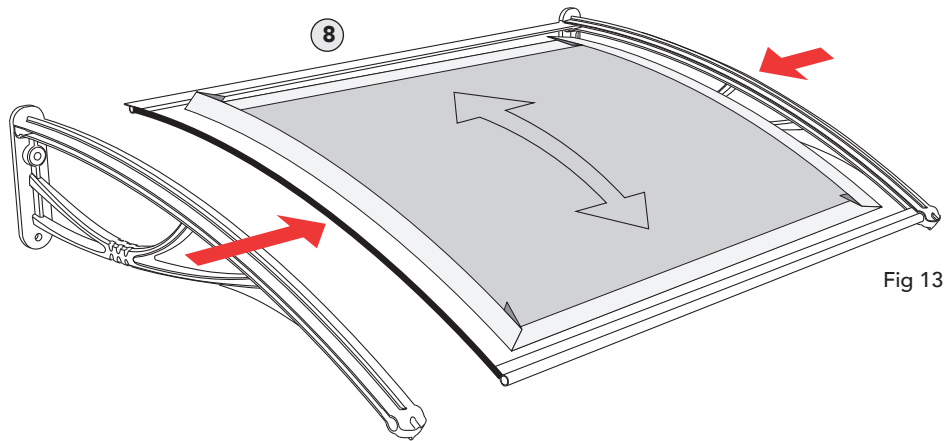

Fig 13

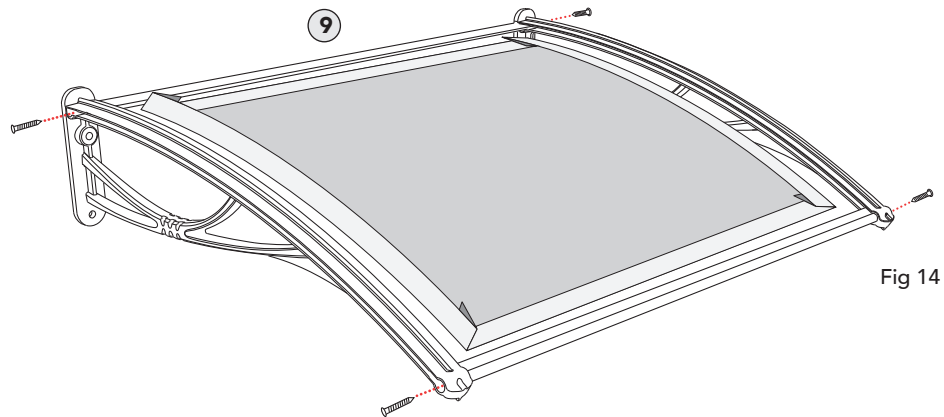

Fig 14

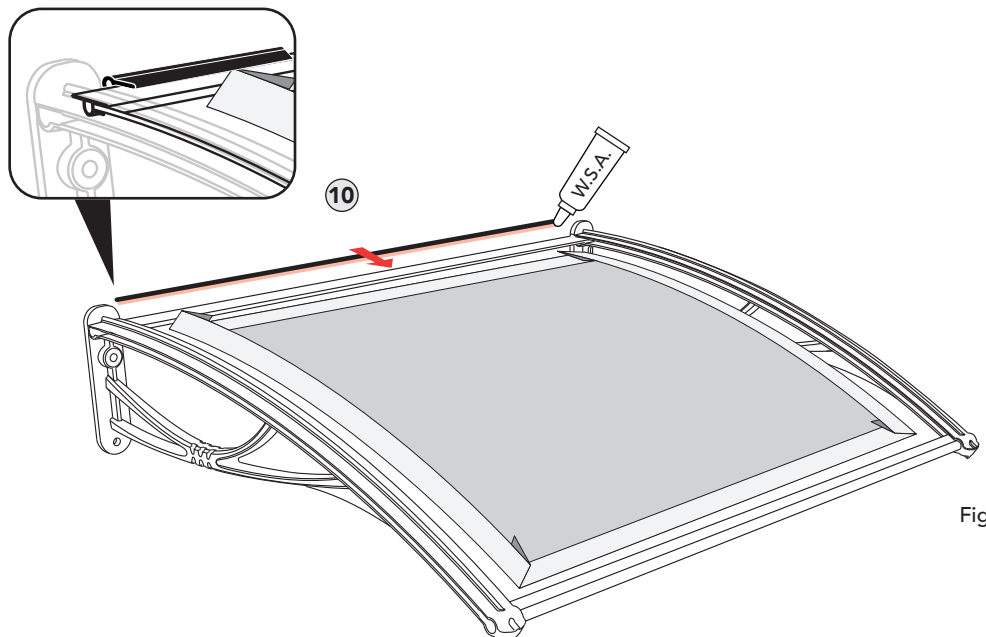

Fig 15

## COMPLETING ASSEMBLY

- ⑪ Carefully peel away the protective film from both the top and bottom of the polycarbonate sheet.

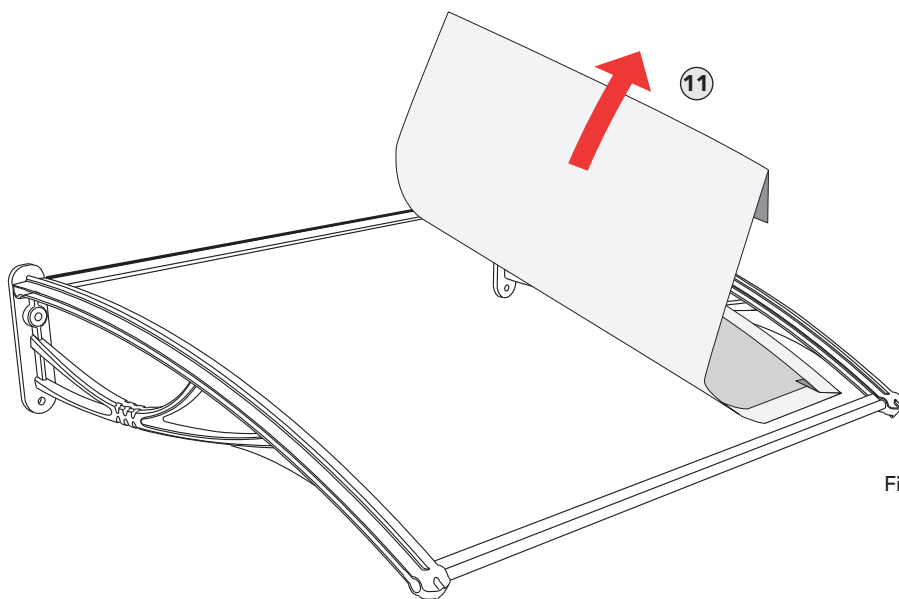

Fig 16

# AWNING INSTALLATION

## MARKING & PRE-DRILLING

- 1 With a helper, hold the assembled awning in place over the desired installation area. Ensure to use a level for proper finish.
- 2 With a marker/pencil mark the bracket mounting hole positions.
- 3 Using a power drill and drill bit, drill through your wall surface ensuring your pilot holes go through main structural supports.

**CAUTION: DO NOT** drill where electrical, gas, or water supply lines may exist.

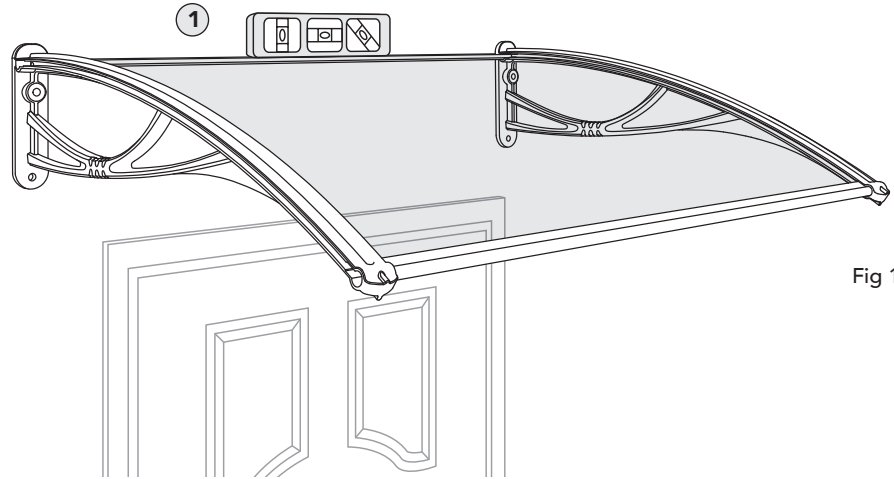
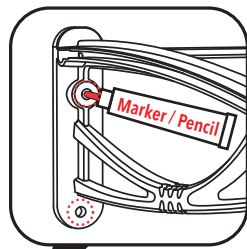

Fig 17



2

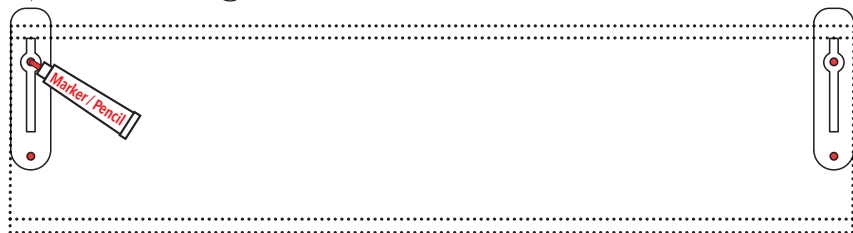
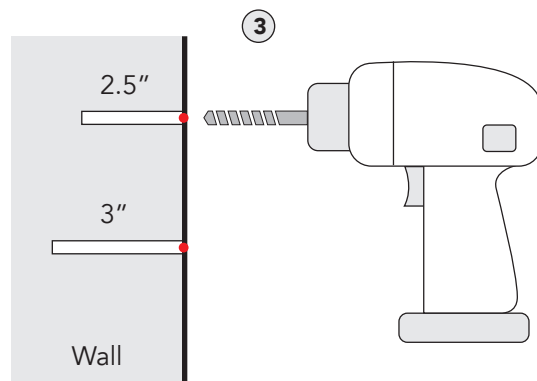
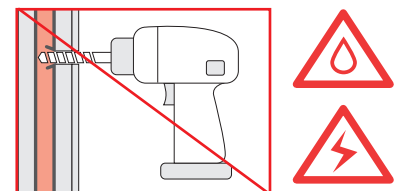

Fig 18



3



# AWNING INSTALLATION

## MOUNTING THE AWNING

- ④ Apply slow curing outdoor silicone directly into the pilot holes.

- ⑤ Align the awning brackets to pilot holes and insert the Lag Screw and Washer (illustrated).

Use a level to ensure the awning is level before tightening the mounting hardware.

**NOTE:** for solid masonry instructions, please visit [www.advaning.com](http://www.advaning.com) or request from [service@advaning.com](mailto:service@advaning.com)

- ⑥ Securely tighten the lag screw with the wrench/socket wrench.

- ⑦ Apply slow curing outdoor silicone around the lag screw.

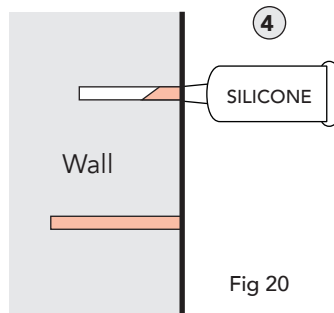

Fig 20

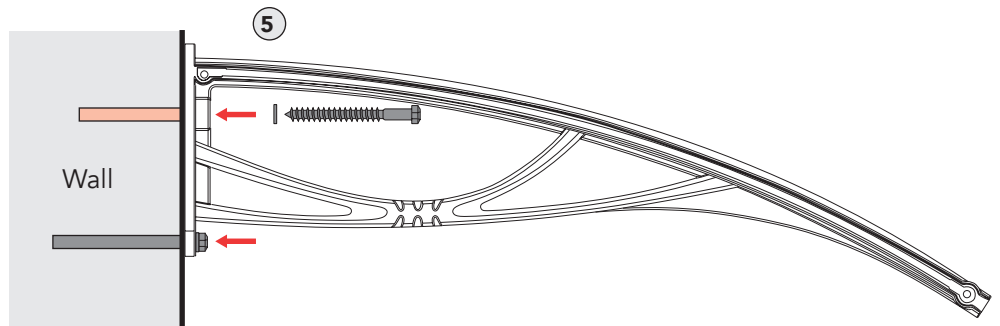

Fig 21

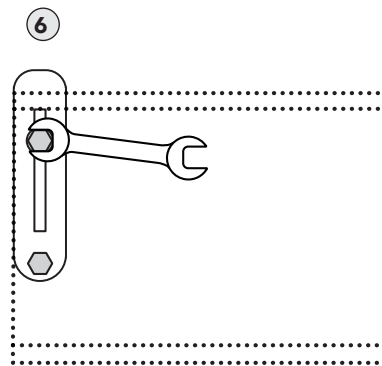

Fig 22

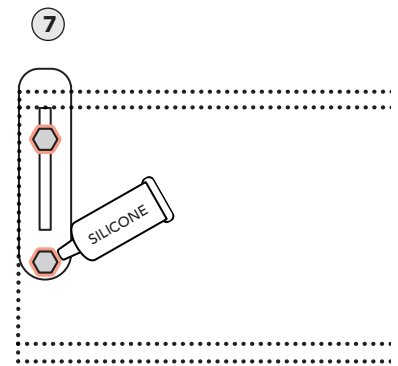
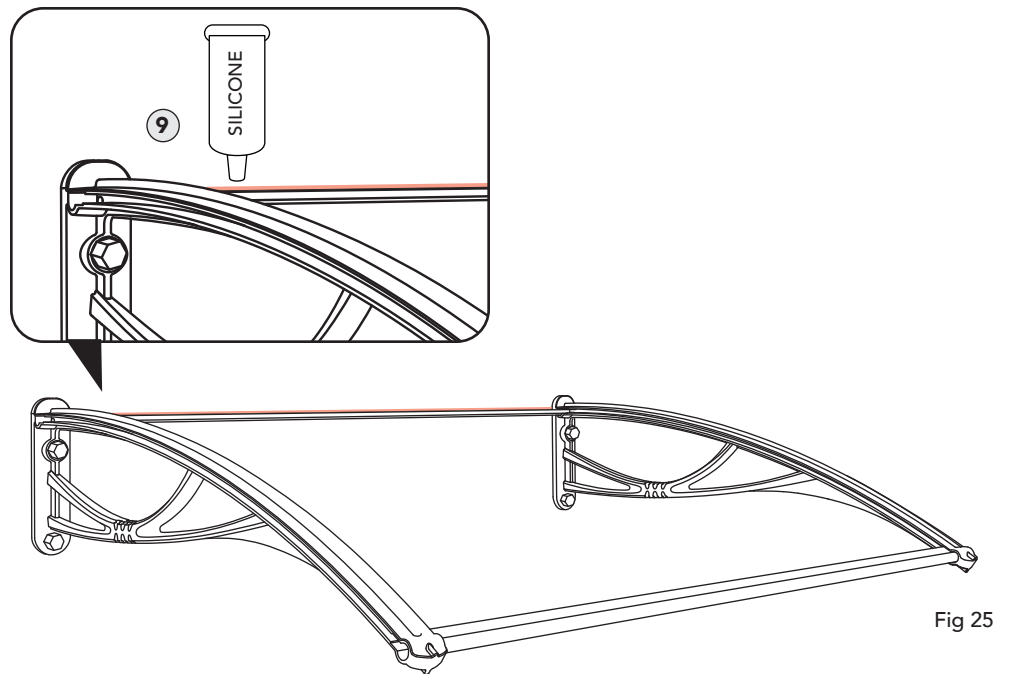
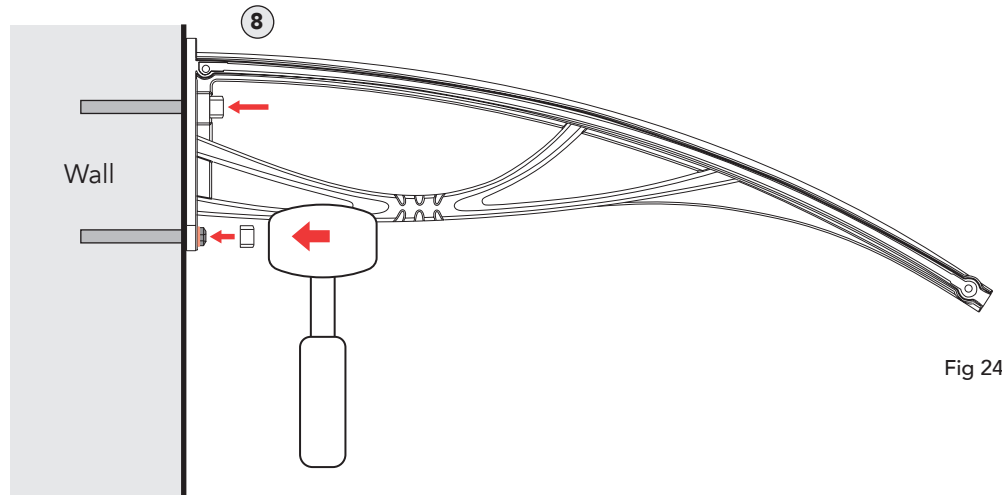

Fig 23

# AWNING INSTALLATION

## FINISHING & WEATHER PROOFING

- ⑧ Cap each lag screw with a Mounting Hardware Cap by gently tapping in place with a rubber mallet.
- ⑨ Apply a bead of slow curing outdoor silicone to the wall and Back Bar connection.



# CONNECTING MULTIPLE AWNINGS

**NOTE:** One properly assembled awning can be used as the template for all hole placement/markings by overlapping the bracket holes along the run length.

- ① Follow all steps to assemble and install one awning (Labeled 1)
- ② Assemble the second awning (Labeled 2) partially, leaving the connection side incomplete.
- ③ Tap the end of the second awning towards connecting bracket ensuring the polycarbonate and gasket insert into the Bracket inset groove.

A ratchet tie down can be used to combine the two awnings by slowly ratcheting the two awning together.

**CAUTION:** The ratchet tie down can cause irreparable damage if overtightened.

- ④ Using the second awnings bracket as guide, drill pilot holes. Follow all installation steps from page 12, Step 4 ~ 9 to complete.

**TIP:** Assemble one awning and measure installation area to ensure the run length and bracket placement will allow a continuous run.

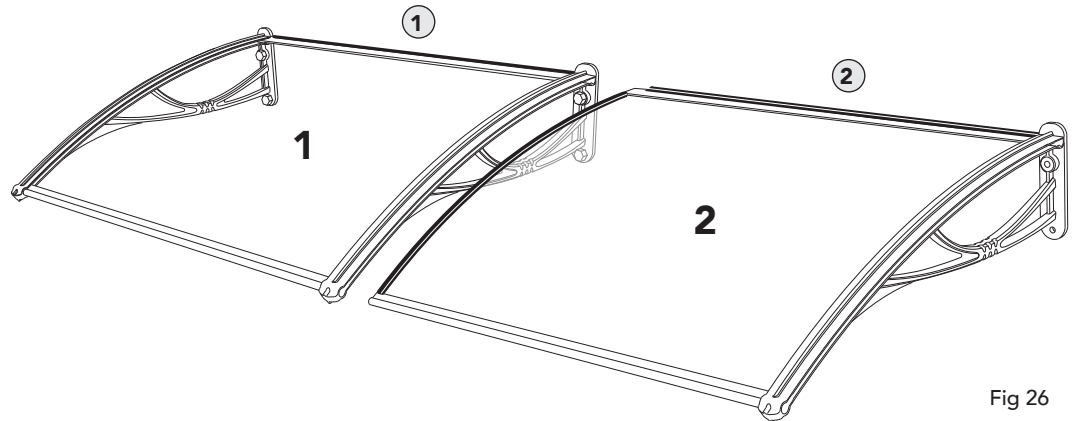

Fig 26

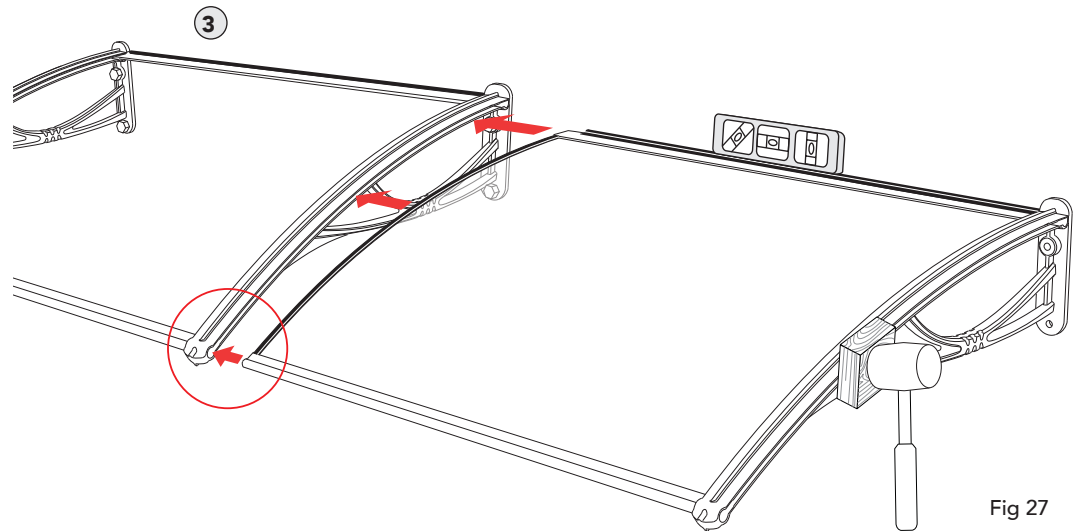

Fig 27

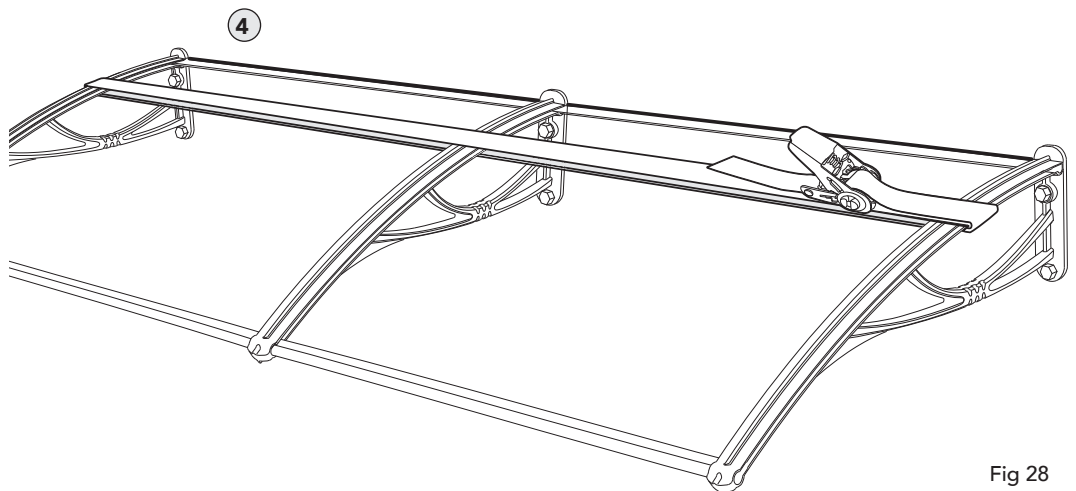

Fig 28

## CARE AND MAINTENANCE

### CLEANING

Cleaning the polycarbonate on your awning can be achieved with a simple solution of mild soap and water (1 part soap to 2 parts water) and a standard garden hose with a pressure nozzle to remove any accumulated dust, dirt, or debris. A specialty polycarbonate cleaner can be used, however, we recommend testing a small section before proceeding to entire polycarbonate. Never use acetone, abrasive cleaners, or other detergents to clean the awning.

### CARE AND MAINTENANCE

Advaning recommends an annual inspection of the screw connections and seal condition. Tighten and replace parts or reapply silicone as needed. All parts can be easily obtained from Advaning should there ever be a need for replacement.

### SNOW LOADS

Although the awning is made to handle significant loads, we recommend clearing accumulated and packed snow whenever possible. A long handled squeegee can be used to assist with removing excess snow. Please visit [www.advaning.com](http://www.advaning.com) for full independent weight capacity test results.



# WARRANTY AND CUSTOMER SERVICE

## **ADVANING 1-YEAR LIMITED MANUFACTURER'S WARRANTY FOR PN SERIES AWNINGS**

Advaning warrants all Advaning PN Series original products, sold and installed within the United States of America and Canada, to be free of defects in materials and workmanship. This warranty only applies to the original owner or purchaser of the product and is only effective on a basis for twelve (12) months or one (1) year from the date of purchase.

Any defects or issues presented to Advaning within the warranty period will be handled by Advaning Customer Service within a reasonable time.

The entire awning framework, including polycarbonate sheet, brackets and parts (page 3 of the Owner's Manual), is covered under the limited warranty.

Powder coated finishes and painted finishes are excluded and are NOT covered under this limited warranty.

During the warranty period, owners in Canada, Hawaii, Alaska, and Puerto Rico are covered for parts and replacements at no charge. However, the owner would assume all shipping and handling and applicable duties and taxes. Advaning's warranty does not cover any return shipping or prepaid return labels.

Should the original owner/purchaser submit a claim within the warranty period from the date of the purchase and after being deemed defective by Advaning, will the warranty claim be resolved by either of the following:

A. Defective components are replaced (shipping charges may apply).

and/or

B. Detailed correctional/resolving instructions will be provided.

## **EXCLUSIONS AND LIMITATIONS OF WARRANTY**

ANY MODIFICATIONS OR ALTERATIONS TO THE PRODUCT WILL VOID THIS WARRANTY.

ADVANING, INCLUDING ITS SUBSIDIARIES AND AFFILIATES, SHALL NOT BE RESPONSIBLE IN ANY MANNER WHATSOEVER FOR INJURY, DEATH OR DAMAGE TO PROPERTY AS A RESULT OF INTENTIONAL OR ACCIDENTAL MISUSED FOR PURPOSES FOR WHICH THE PRODUCT WAS NOT DESIGNED FOR.

The warranty will be in effect once the awning is fully paid for.

Advaning is not responsible for damage due to faulty modifications, installation, or re-installation. Advaning assumes no liability for damage to the structure to which the awning is attached, or to the property located underneath the awning. This limited warranty does not cover damage from ice, snow, hail, high winds, vandalism, neglect, improper use, or any natural disaster. This limited warranty does not cover degradation due to salt corrosion, oxidation, and chipping or peeling of the paint.

## **What is Not Covered by the Advaning Limited Warranty**

This warranty is non-transferable and does not cover product purchases from the initial buyer to a third party. This warranty does not cover incidental damages, such as loss of time, loss of use, or installation costs of defective, repaired, or replaced products. This warranty does not cover products that have been damaged or rendered defective as a result of:

# WARRANTY AND CUSTOMER SERVICE

- (a) Neglect, abuse or misuse.
- (b) Modification of the original product.
- (c) Improper use or installation using products not manufactured by Advaning.
- (d) Service provided by anybody other than Advaning.
- (e) Abnormal mechanical or environmental conditions.
- (f) Unusual physical or electrical stress -including failure or fluctuation of electrical power, lighting, static electricity, fire, tornadoes, or other natural disasters.

## WARRANTY CLAIMS:

If you experience a problem with your Advaning product, please contact Advaning Customer Service representatives by email at [service@advaning.com](mailto:service@advaning.com), by phone at **714-622-2600** or by submitting a Warranty Claim via our website, [advaning.com/warranty-support](http://advaning.com/warranty-support)

Advaning Customer Service is available Monday through Friday from 8:30 a.m. to 4:00 p.m. PST

- Prior to contacting Advaning for warranty claims, please have your model name/number, \*original proof of purchase, photos and/or videos along with a description of the issue experiencing ready for our Customer Service team to assess.
- Submitting a claim will not extend or alter the warranty coverage period.
- Work performed by a third party or not authorized by an Advaning agent voids the warranty.

\*Original Proof of Purchase: A valid sales/purchase receipt is required with authorized reseller/retailer name, the purchase date, and the model number of the item purchased.

## SHIPPING DAMAGE/MISSING PARTS CLAIMS

On the occasion of a damage claim caused by the shipper/shipping company, the owner must contact their point of sale and the delivery carrier within 3-days of signing for the delivery in order to make a claim.

Likewise, there is a 7-day window from the time of delivery to report missing parts to Advaning.

Failure to report shipping damage and missing parts in a timely manner and in accordance with the shipper/carrier guidelines may result in the owner incurring all costs.

THIS WARRANTY IS EXCLUSIVE AND IS IN LIEU OF ANY AND ALL OTHER WARRANTIES, EXPRESSED OR IMPLIED. NO IMPLIED WARRANTIES OF MERCHANTABILITY OR FITNESS FOR A PARTICULAR PURPOSE ARE GIVEN, ANY AND ALL LIABILITY FOR BREACH OF ANY IMPLIED WARRANTY OR WARRANTY CREATED BY LAW IS DISCLAIMED. Some states do not allow limitations on how long an implied warranty lasts, so the above limitation may not apply to you. UNDER NO CIRCUMSTANCES SHALL ADVANING, INCLUDING ITS SUBSIDIARIES AND AFFILIATES BE LIABLE FOR INCIDENTAL OR CONSEQUENTIAL DAMAGES WITH RESPECT TO ECONOMIC LOSS, INJURY, DEATH OR PROPERTY DAMAGE, WHETHER AS A RESULT OF BREACH OF THIS WARRANTY, NEGLIGENCE OR OTHERWISE. Some states do not allow the exclusion or limitation of incidental or consequential damages, so the above limitation or exclusion may not apply to you in whole or in part. This warranty gives you specific legal rights. You may also have other rights that vary from state to state.



## CONTACT INFORMATION

### Product Questions?

Please contact Advaning via email at [service@advaning.com](mailto:service@advaning.com),  
by phone at 714-622-2600, or by chat on our website;  
[www.advaning.com](http://www.advaning.com)

Advaning Customer Service is available Monday through  
Friday from 8:30 a.m. to 4:00 p.m. PST

[www.advaning.com](http://www.advaning.com)