

# PN Series Polycarbonate Awning

Applicant

**ADVANING**<sup>®</sup>  
ADVANCED AWNINGS & SHADES

Test Period: **01/2019**

Facility: **ATS**

Report No.: **307869 #102858991GRR**

## Objective

The purpose of this test is to determine the point of failure for the product with direct stress applied by accumulated weight. Simulating snow fall collecting on top of the product.

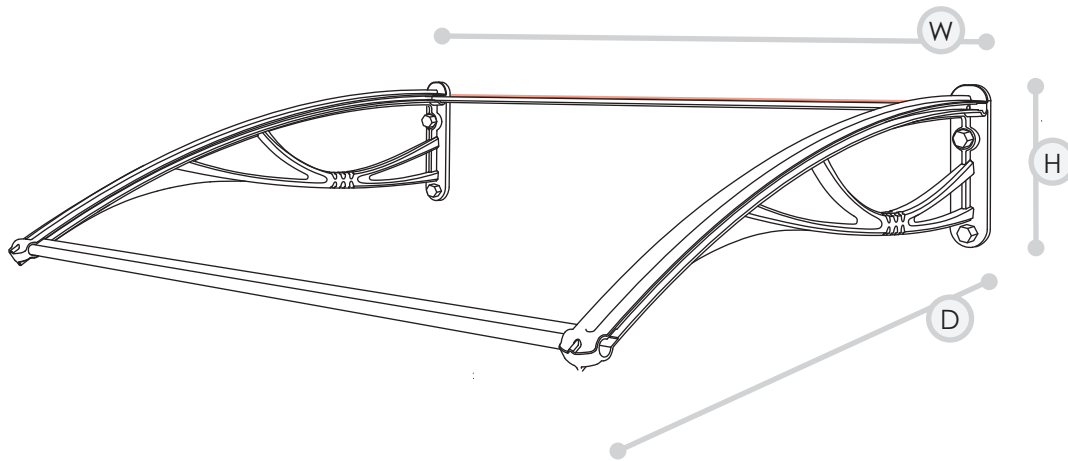

## Monitored Parameters

Value	Description	Units	Method	MU
Weight	Amount of weight placed on top of product before failure.	LBS.	Scale	±5%

## Test Results

Submitted Test Model Sizes	Model Size DepthxWidthxHeight	Weight Capacity Results
47"to 55"	31.5"x47.2"x11" 31.5"x55"x11"	200 LBS

## Test Procedure

1. Install the product per the installation instructions.
2. Evenly distribute 10 lbs. bags across the top of product.
3. Continue adding weighted bags until product fails.
4. Upon failure, weigh the bags to verify and record total load.