

SLIM GRAY SERIES Retractable Awning

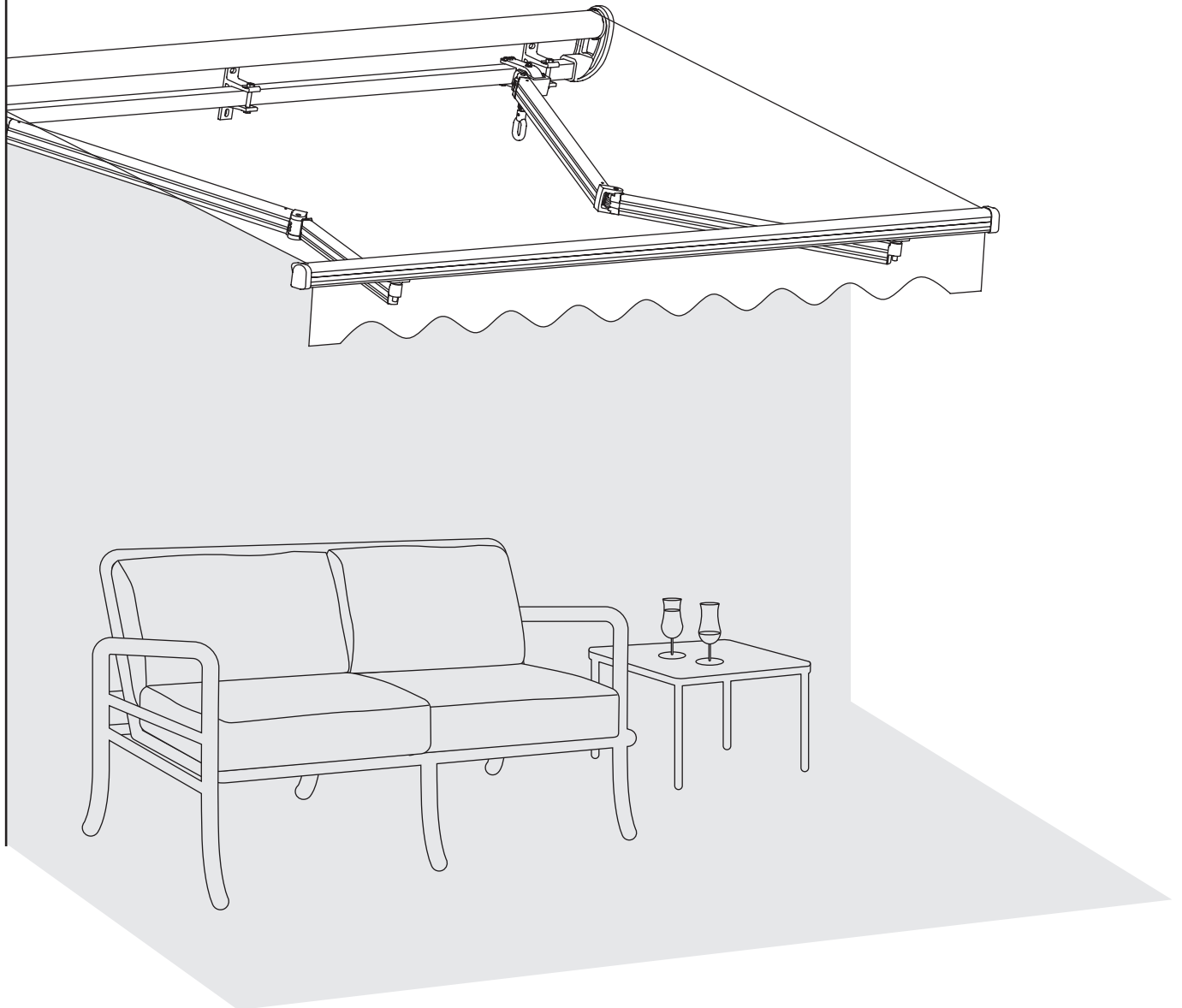

Owner's Manual

For your safety and the safety of others, please read all of the instructions and warnings in this manual carefully before proceeding with installation and use.

TABLE OF CONTENTS

Safety instructions and warnings.....	1-2
Package contents and parts	3
Required tools	4
Awning terminology and location	4
Installation	
Bracket placement reference chart	5
Pre-Installation guide	6
Install wall brackets	
Standard stud installation	7-8
Masonry installation.....	8-10
Installing awning onto brackets.....	11
Ready your awning.....	11
Operation	
Manual operation	12
Fabric rolling direction	12
Adjust awning pitch	13
Maintenance.....	14
Warranty and contacts.....	15-16

SAFETY INSTRUCTIONS



In order to avoid accidental injury or damage, **DO NOT** remove arm safety restraints until instructed.

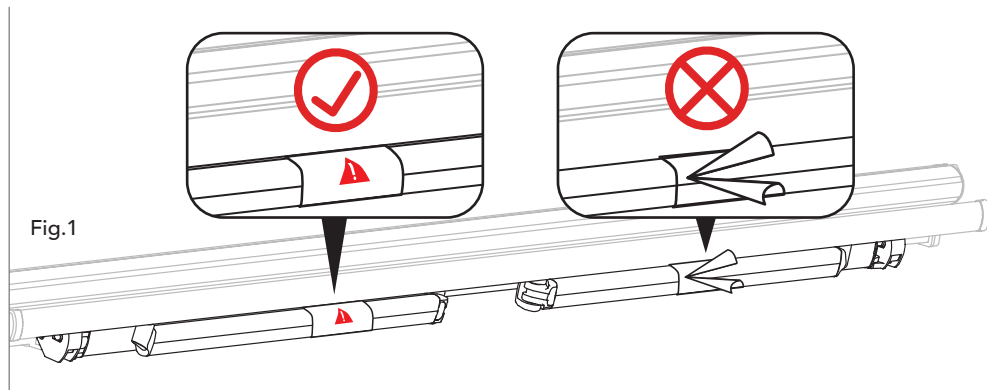

CAUTION

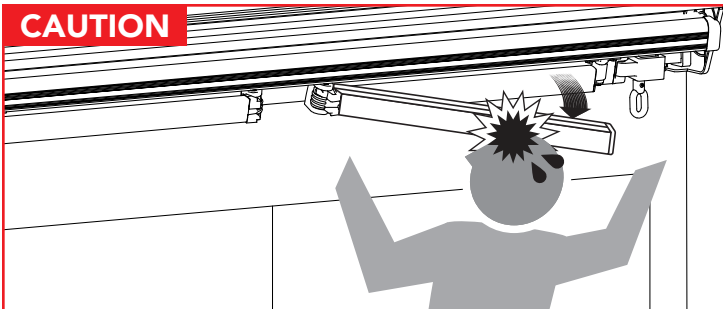

The awning arms contain tensioned cables. Always use caution, securely tie the awnings arms to the awning when performing installation, adjustments, or repairs. Sudden movement of tension arms can result in serious personal injury, product and/or property damage.

SAFETY INSTRUCTIONS AND WARNINGS

SAFETY FIRST, PLEASE READ THE FOLLOWING POINTS TO REDUCE THE RISK OF PERSONAL INJURY.

Installation

- Pay close attention throughout the installation process to ensure that the Advaning awning is installed properly and according to the safety guidelines outlined herein.
- Do not attempt installation while under the influence of alcohol or drug substances.
- Do not remove the safety restraints from the awning's lateral arms until instructed to do so. The arms contain tensioned springs and may release very quickly. Always ensure no persons or objects are directly in arm projection path at all times.
- Do not proceed with an installation if you feel that you cannot properly and safely complete, please seek professional help.
- Always wear protective gear and gloves when handling sharp metal parts.
- Only perform installation/maintenance/cleaning in dry and optimal weather conditions.
- 2 or more persons are recommended for installation. Installation will require to lift the assembled awning onto the brackets. Ensure help is available to help lift.

Usage

- Only use Advaning recommended accessories and original replacement parts.
- Only perform installation/maintenance/cleaning in dry and optimal weather conditions.
- Do not place any heat source or open flame under or near the awning.
- Do not place, hang, or stand objects or persons on the awning itself. Doing so can damage the awning or cause severe personal injury and in extreme cases death.
- Do not carry out any maintenance other than what is shown in the manual. For any issues that are not covered in this manual, please seek support from Advaning Customer Service.
Email: service@advaning.com
- The product should only be operated by an adult that understands all the functions and operations. Please keep unsupervised children away from playing with the awning or its parts.
- The product should be used only as described in this Advaning Owner's manual.

DO NOT keep the awning open during:
A: RAIN
B: SNOW
C: STRONG WIND
D: UNSUPERVISED PERIODS

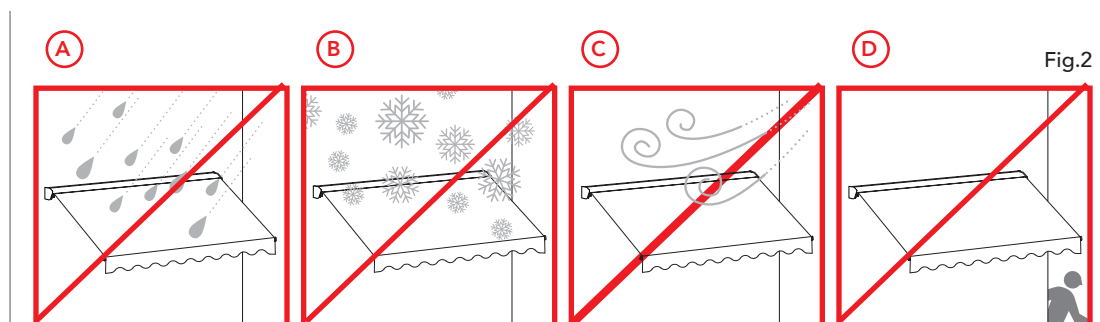

PACKAGE CONTENTS AND PARTS

Before attempting your install, please ensure that the package contains all parts and qty's as listed for your awning size.

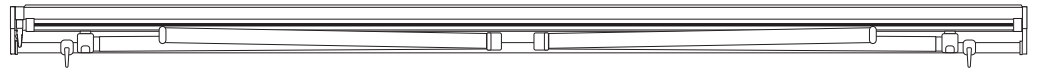

Awning unit Qty: 1

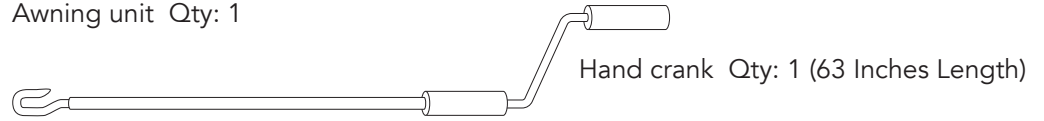

Hand crank Qty: 1 (63 Inches Length)

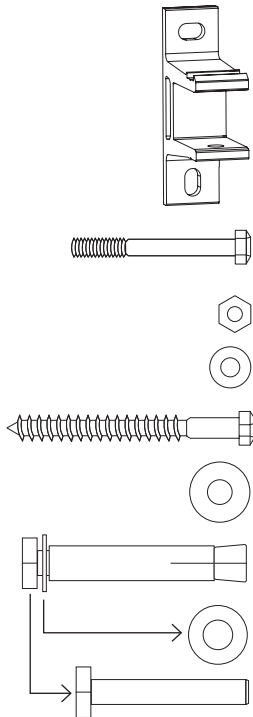

Model Size	12'~14'	
Parts name	Quantity	
Wall bracket set	Wall bracket	3
	Retaining hex bolt	3
	Retaining nut	3
	5/16" washer	3
3/8"x4" Lag screw		6
3/8" Flat washer		6
Expansion bolt set	Expansion bolt	6
	Washer	6
	Hex bolt	6

OPTIONAL DUAL-USE BRACKET FOR SOFFIT MOUNT

Sold Separately
Part# ZCA-DMB-S1

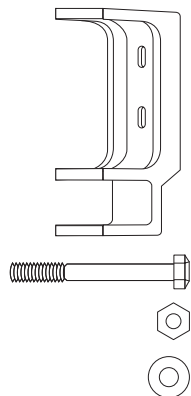
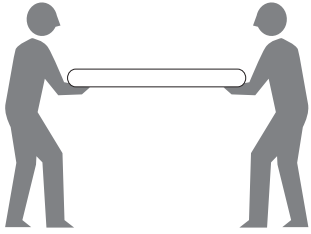

Fig.3

REQUIRED TOOLS



Minimum 2 people to install



REQUIRED TOOLS

- ① Marker / pencil
- ② Measuring tape
- ③ Electronic Stud finder
- ④ Chalk line / laser level
- ⑤ Level
- ⑥ 3/8" socket wrench
- ⑦ *Wood Drill Bit
- ⑧ 1/2" Masonry Drill Bit
- ⑨ Power Drill / Hammer Drill (Masonry)
- ⑩ Ladders (2)

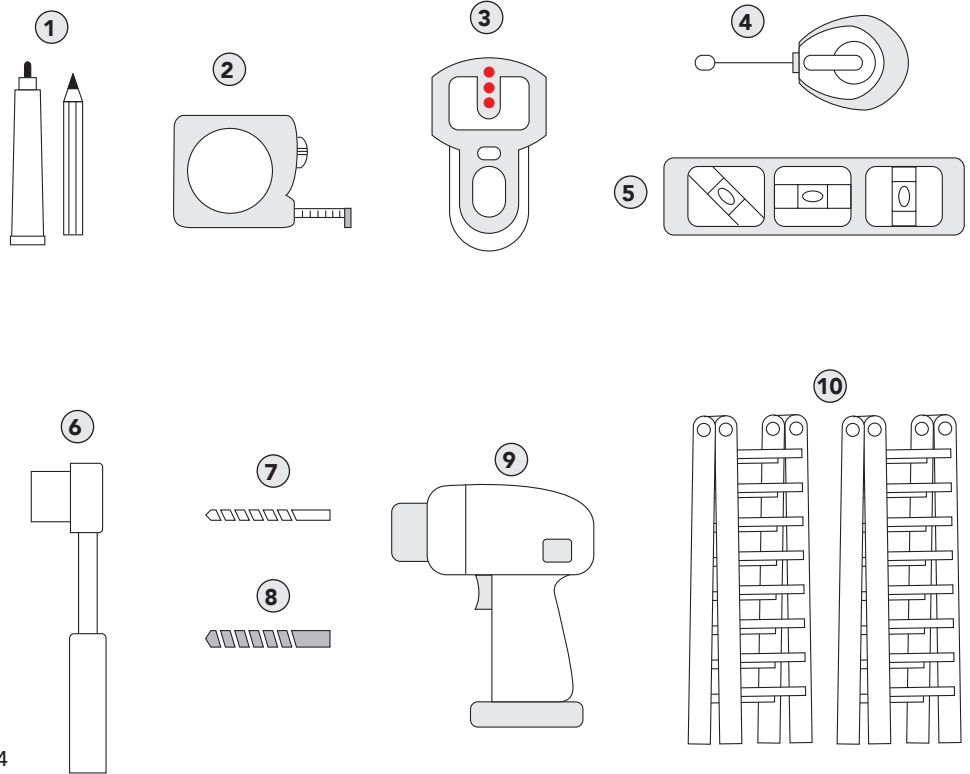

Fig.4

*Dependent on wood species: 1/4" ~ 9/32" drill bit.

AWNING TERMINOLOGY AND LOCATION

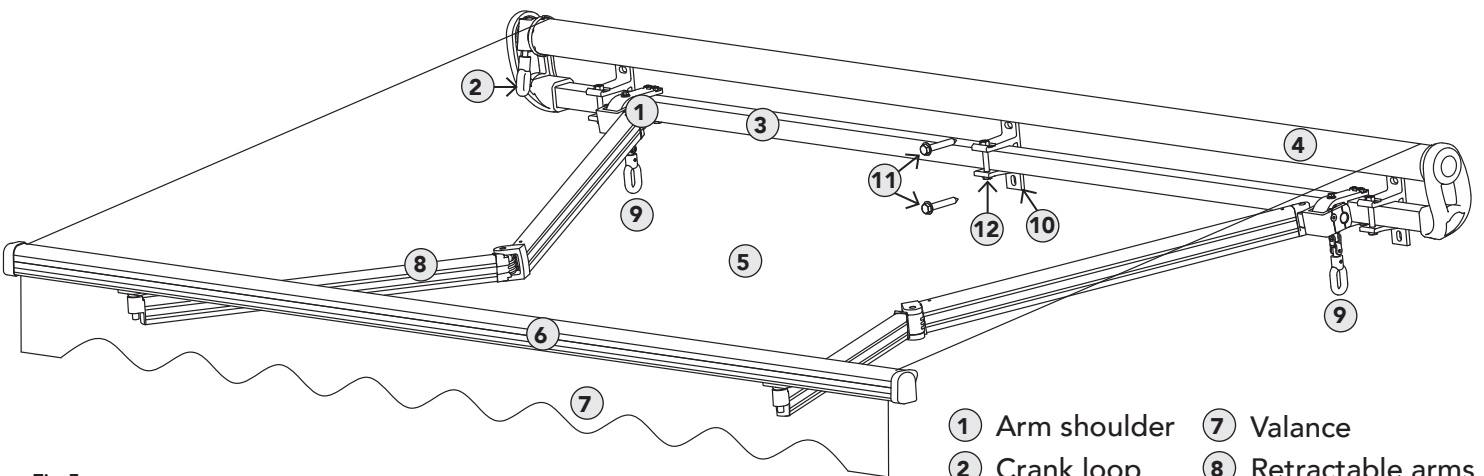

Fig.5

- ① Arm shoulder
- ② Crank loop
- ③ Torsion bar
- ④ Roller tube
- ⑤ Awning fabric
- ⑥ Front bar
- ⑦ Valance
- ⑧ Retractable arms
- ⑨ Easy Pitch™ loop
- ⑩ Wall bracket
- ⑪ Installation hardware
- ⑫ Retaining bolt

INSTALLATION

BRACKET PLACEMENT REFERENCE CHART

Use the illustrations below for optimal bracket placement.

- Ⓐ Left awning shoulder
- Ⓑ Right awning shoulder

IMPORTANT

ALL BRACKETS MUST BE MOUNTED DIRECTLY ONTO WALL STUDS OR OTHER MAJOR STRUCTURAL SUPPORTS.

FOR OPTIMAL BALANCE OF THE AWNING WEIGHT DISTRIBUTION, PLEASE ATTEMPT TO FOLLOW THE BRACKET PLACEMENT AS ILLUSTRATED.

NOTE: NOT EVERY INSTALLATION IS IDENTICAL AND MOST STUDS/STRUCTURAL SUPPORTS WILL NOT ALWAYS ALIGN, THE BRACKETS MAY BE MOVED TO BEST SAFELY FIT YOUR SPECIFIC STUD/STRUCTURAL SUPPORT LOCATION WHILE SUPPORTING THE AWNING ONCE INSTALLED.

12 ~ 14 feet awning

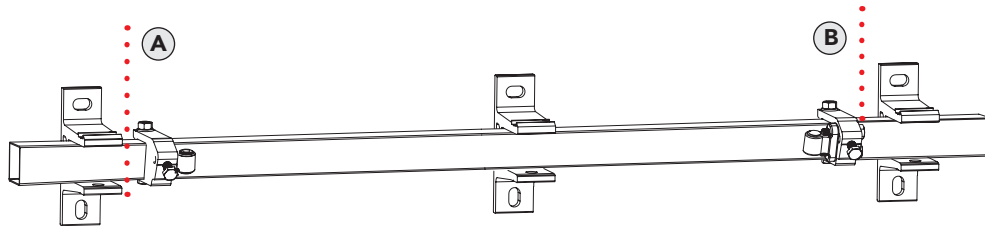

Fig.6

INSTALLATION

PRE-INSTALLATION GUIDE

Locate a position that is

- Ⓐ Recommended: 8 to 10 ft. above the ground/ floor, deck etc.
- Ⓑ Recommended (for wall mounts only): Minimum of 1 inch clearance below the roof/eave/overhang etc.
- Ⓒ Critical: Minimum of 10 inches clear vertical run length (no obstructions) – depending on awning size.



Run length should be free and clear of any obstructions along the entirety of planned install site.

Personal & specific structural physicalities may require deviation from the recommended measurements, consult with a professional installer who can best assess your installation site and ensure a safe and full function of the awning once installed.

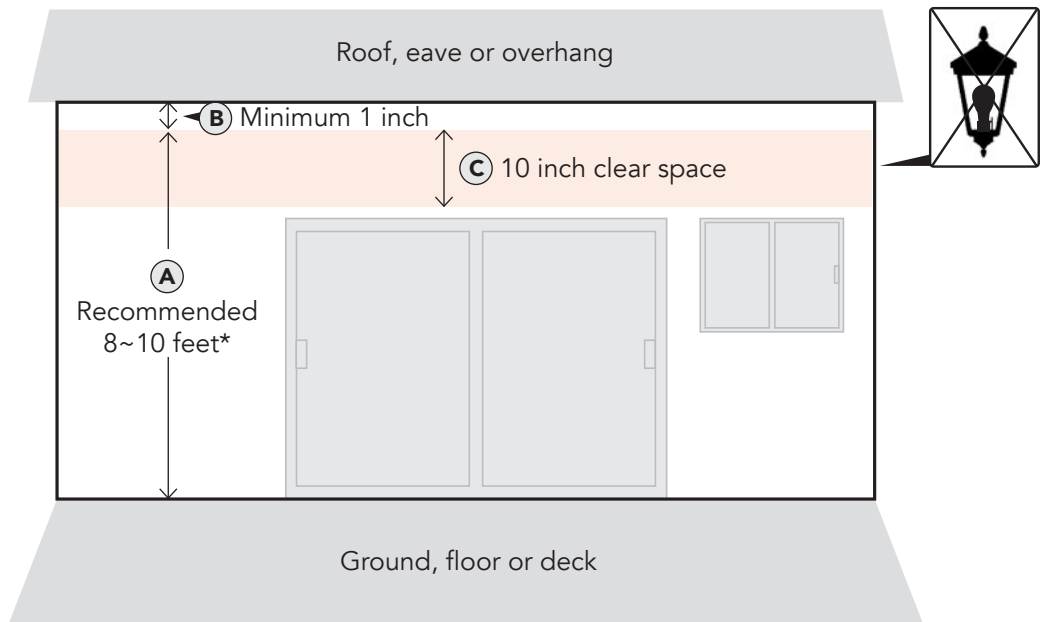

Fig 7

Side view

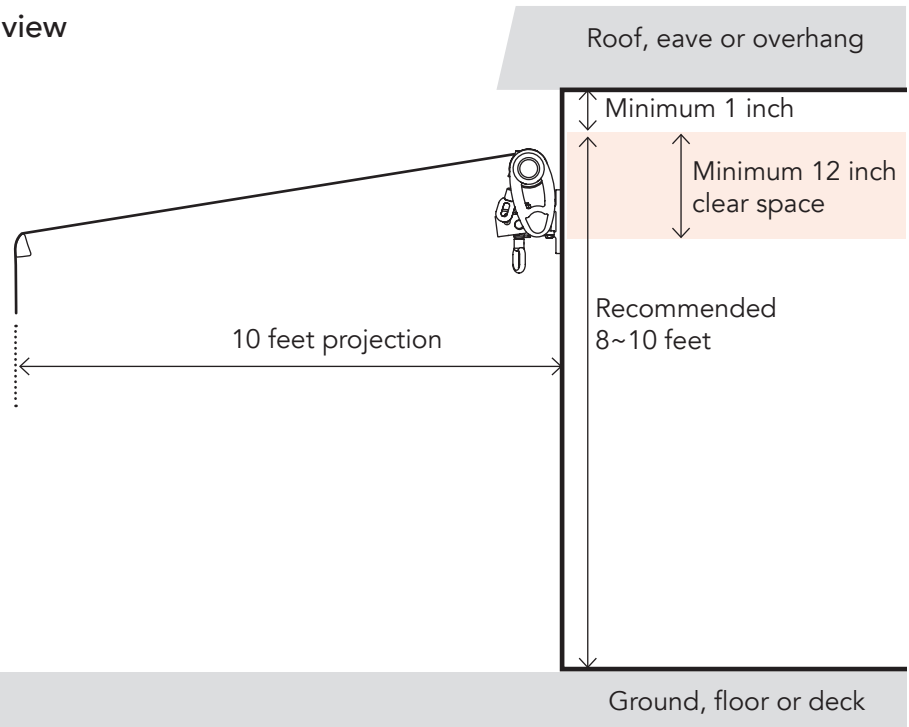

Fig 8

INSTALLATION

INSTALLING WALL BRACKETS

General stud framing installation

- ① Measure and mark where the top of your awning bracket will be placed.
- ② Use a level and chalk line or laser level to mark your bracket guide line.
- ③ Locate and mark the center of the wall studs along this line using a stud finder.

*Follow your specific stud finders manufacturer's instructions to properly locate studs.

- ④ Align the top of the bracket to the chalk line.
- ⑤ Align the center of the bracket mounting holes with the center of the stud.
- ⑥ Use a level to make sure the bracket is straight and mark the center of the mounting holes.
- ⑦ Drill mounting pilot holes.

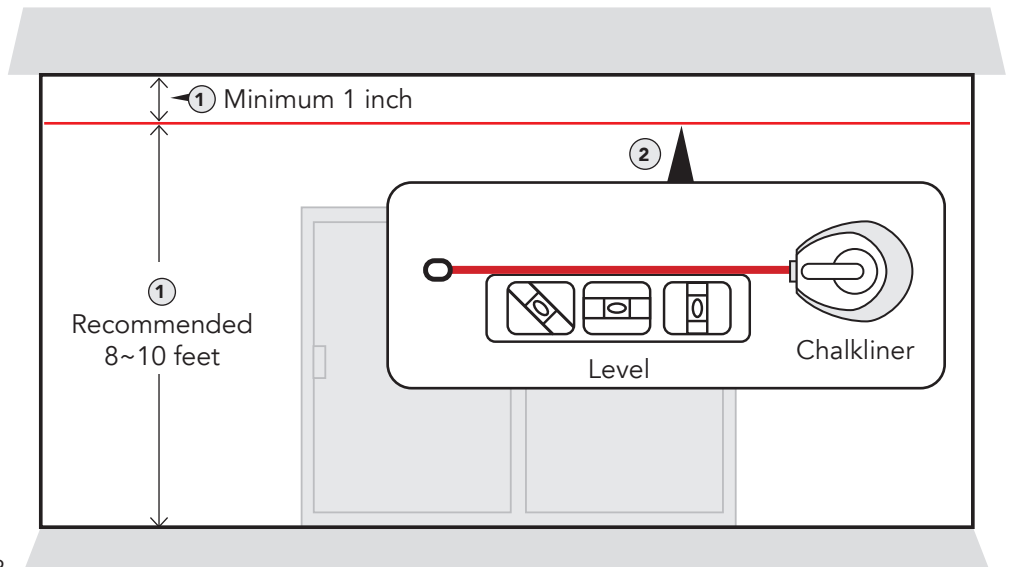

Fig 9

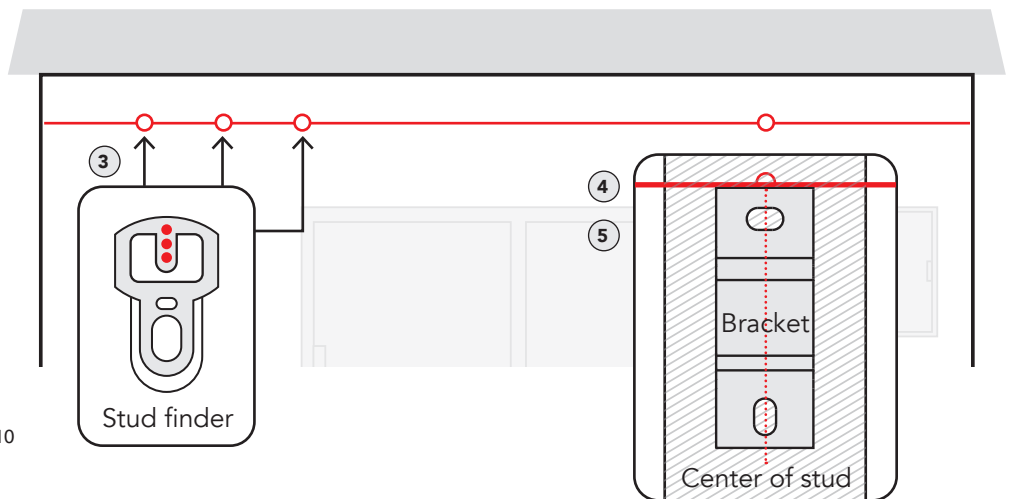

Fig 10

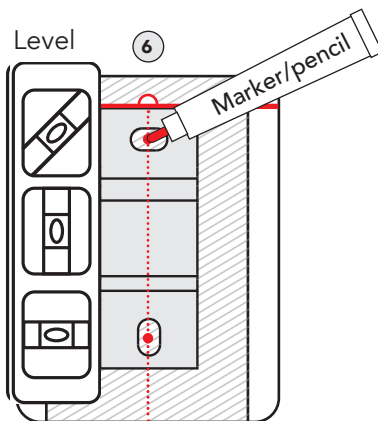

Fig 11

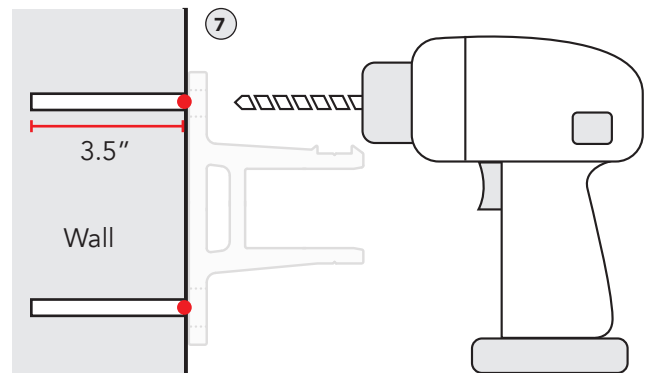

Fig 12

INSTALLTION

- ⑧ Place bracket over pre-drilled holes and use a level to ensure the bracket is leveled and square to line.
- ⑨ Use a lag screw and washer to secure the bracket to your wall/surface, repeat for each bracket.

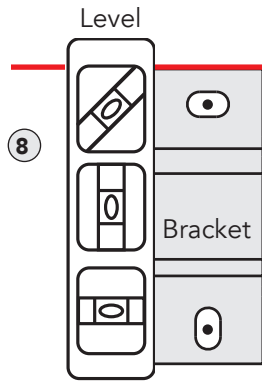

Fig 13

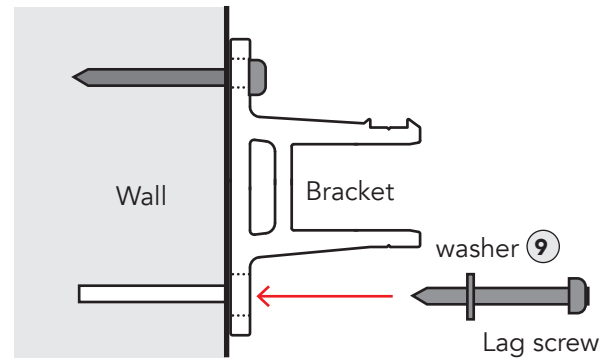

Fig 14

NOTE: For proper installation of brackets on uneven surfaces or siding, use shims or spacers to level the bracket.

Due to a variety of siding finishes/materials, Advaning recommends contacting the siding manufacture for necessary requirements before using shims, cutting or drilling into your siding.

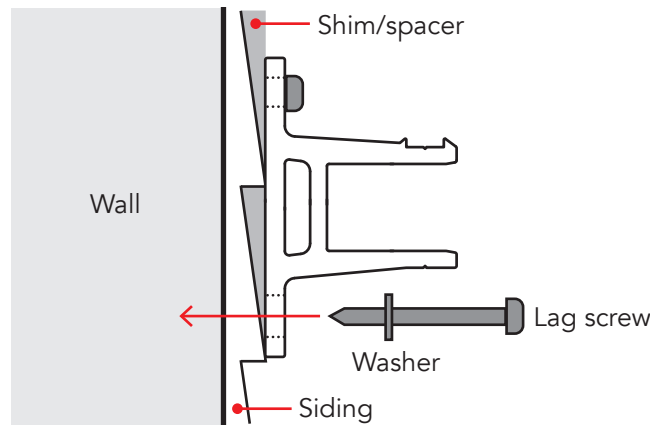

Fig 15

Masonry Installation

General (solid) masonry installation

CAUTION: Brackets must be installed directly onto solid brick or concrete.

Avoid severe personal injury & property damage - Never install brackets to grout, mortar or hollow masonry substrates

Masonry Installation detailed photos and tips available via www.advaning.com

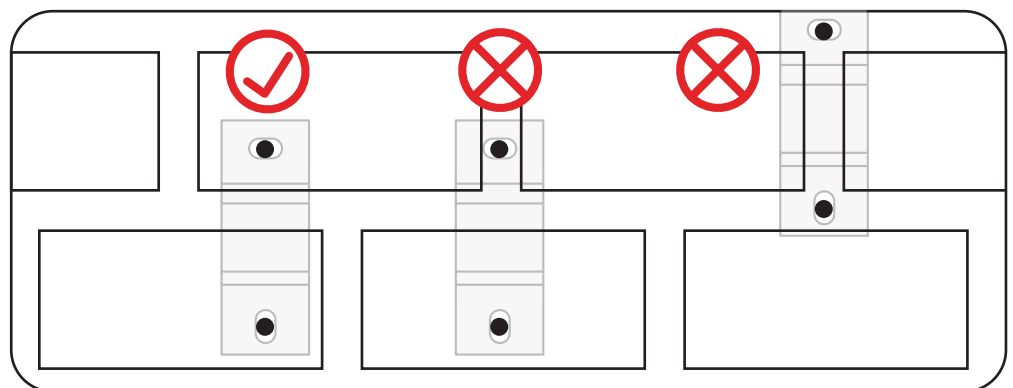

Fig 16

INSTALLATION

- ① Follow instructions for standard installation step 1 and 2 (page 7).
- ② Use the recommended bracket location chart (page 5) to find bracket location for your awning model along the line.
- ③ Align the top of the bracket to the chalk line and use a level to make sure the bracket is straight.
- ④ Mark the center of the bracket mounting holes.
- ⑤ Drill mounting pilot holes.

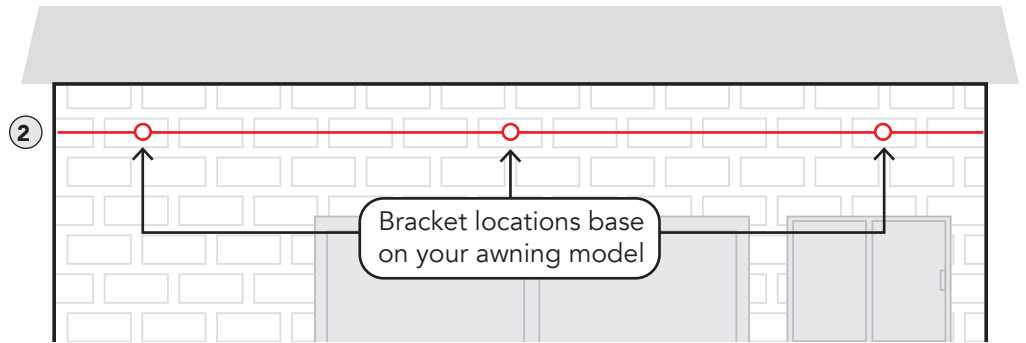

Fig 17

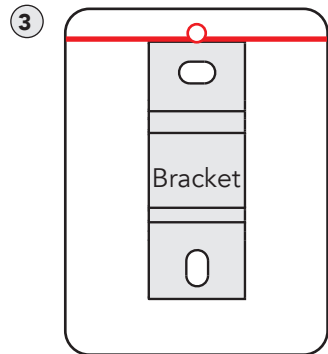

Fig 18

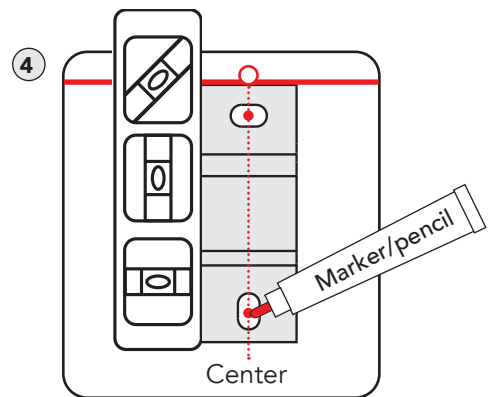

Fig 19

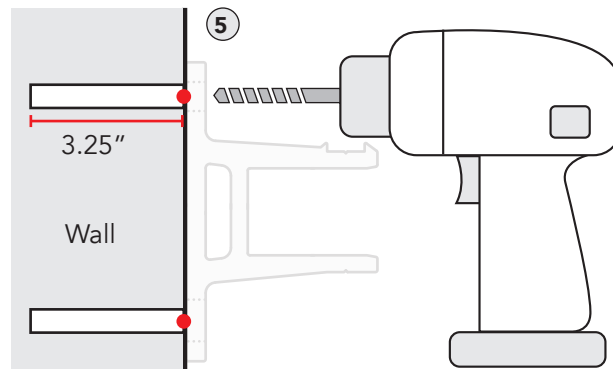

Fig 20

INSTALLATION

- ⑥ Clean the pilot hole and remove excess dust/debris with a vacuum. Insert an expansion bolt set into each hole (a hammer may be used).
- ⑦ Leave the hex bolt head outside of the hole.

Leave the hex bolt head outside of the hole.

CAUTION: Do not over tighten.

- ⑧ Using a socket wrench tighten the hex bolt, this will cause the anchor/wedge to expand and lock the sleeve in place.

- ⑨ Unscrew and remove the hex bolt. Ensuring the sleeve and anchor/wedge are locked within the wall.

- ⑩ Place the wall bracket over the holes and use a level to make sure the bracket is straight.

- ⑪ Re-insert the hex bolt with washer through bracket and into the fixed sleeve.

- ⑫ Tighten the hex bolts to secure wall bracket to surface.

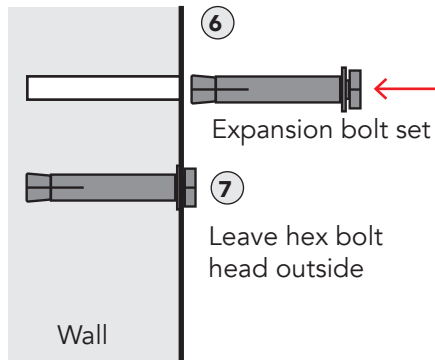

Fig 21

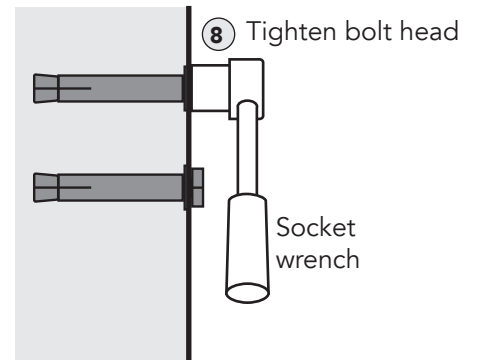

Fig 22

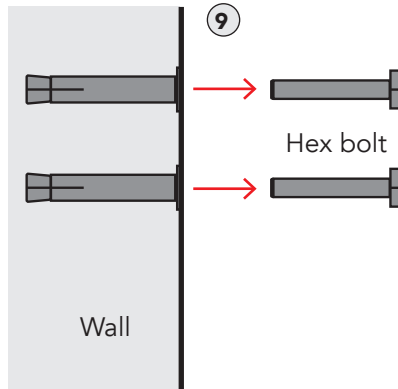

Fig 23

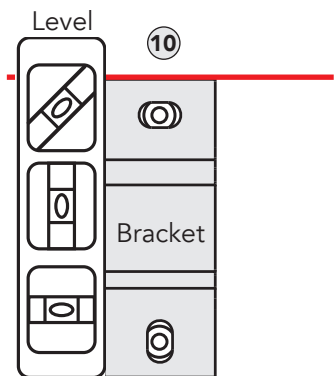

Fig 24

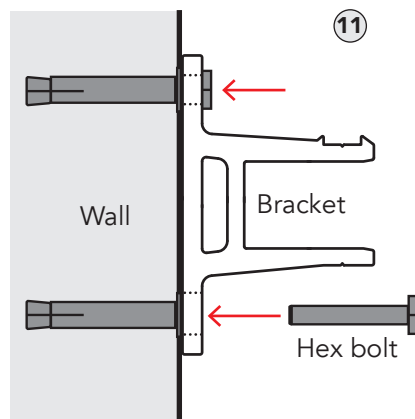

Fig 25

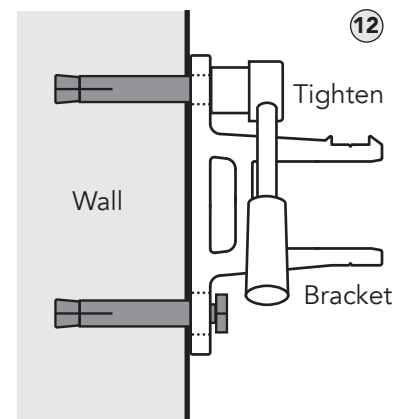

Fig 26

INSTALLATION

INSTALLING AWNING ONTO BRACKETS

- 1 Remove the retaining bolts from each bracket.
- 2 Lift and slide the awning to brackets and slide the torsion bar into the bracket fork.
- 3 Insert the retaining bolt and washer into the bracket fork holes and secure with nut.
- 4 Securely tighten the bolts with a socket wrench.

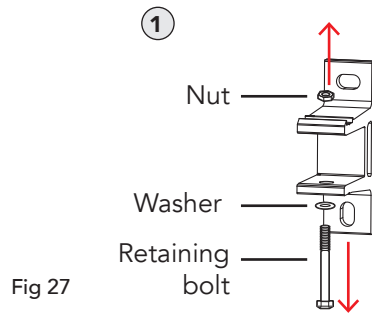

Fig 27

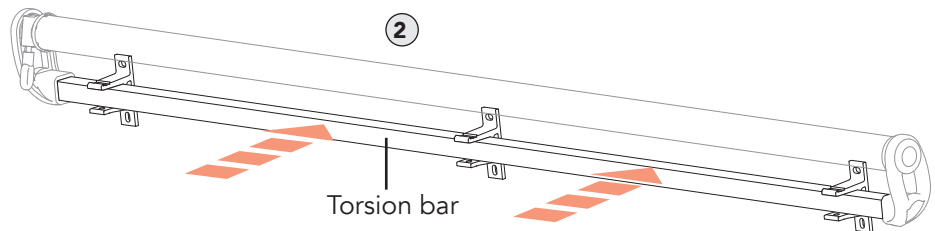

Fig 28

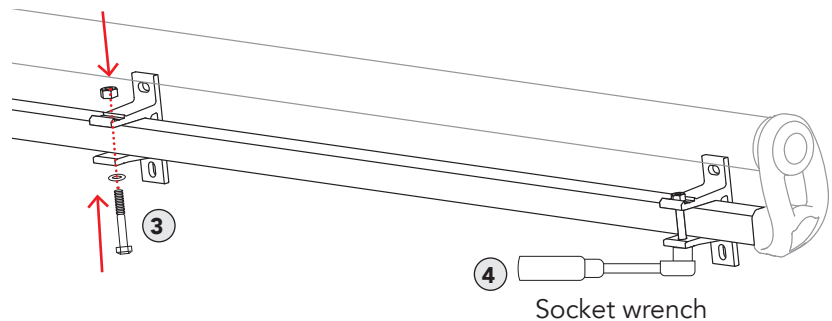

Fig 29

READY YOUR AWNING

Before removing the safety restraints, make sure that no persons or objects are directly in arm projection path.

- 1 Position yourself under the awning.
- 2 With scissors, carefully cut the safety restraints from the arms one at a time. Avoid damaging your awning – Do not use a knife or blade.

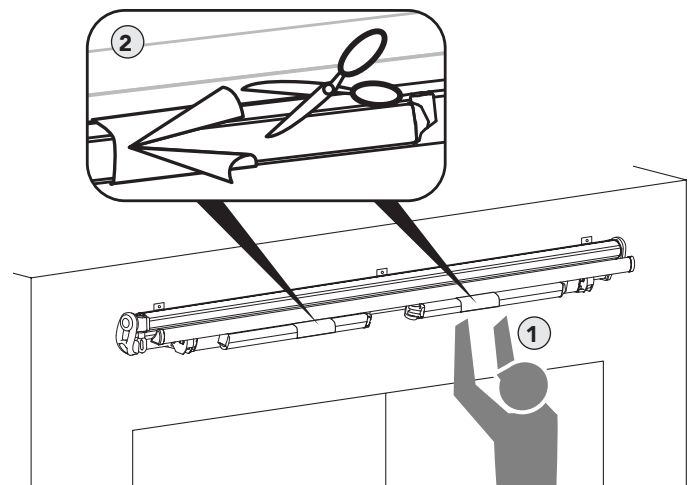

Fig 30

OPERATION

MANUAL OPERATION

- ① Use the hand crank to open the awning fully then close it completely to test for proper operation.
- ② Use the hand crank and open the awning to desired extension.

To keep the fabric taut, always reserve a small portion of the awning fabric on the roller tube

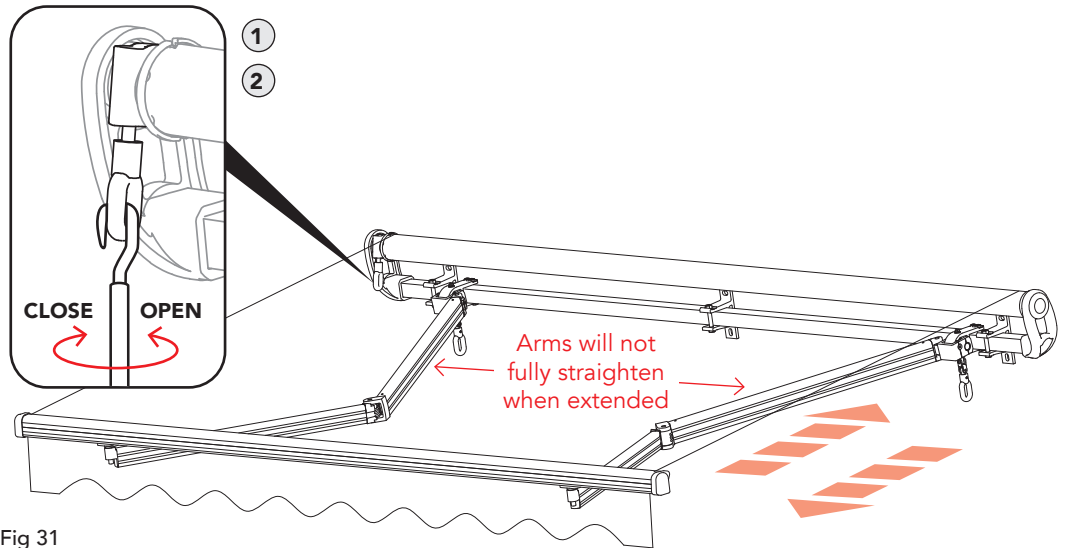

FABRIC ROLLING DIRECTION

Always ensure the fabric is rolled over the fabric roller tube.

Side view

Fig 32

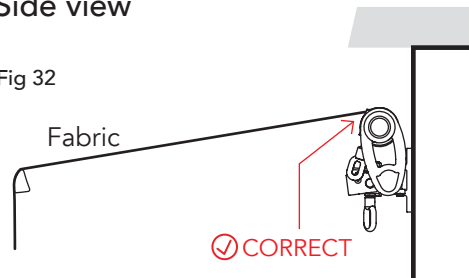
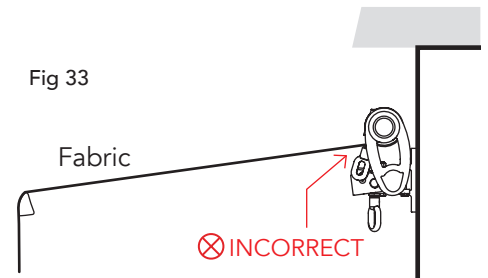

Fig 33



OPERATION

ADJUST AWNING PITCH

- ① Open the awning about 1/3 extension or 2ft out.
- ② With the aid of a helper supporting the front bar of the awning, hook the hand crank through one of the Easy Pitch™ loops.
- ③ Turn the hand crank to adjust the awnings pitch up or down.
- ④ Repeat the adjustment to all Easy Pitch™ loops.
- ⑤ Fully open the awning and with the use of a level ensure the front bar is straight and leveled.

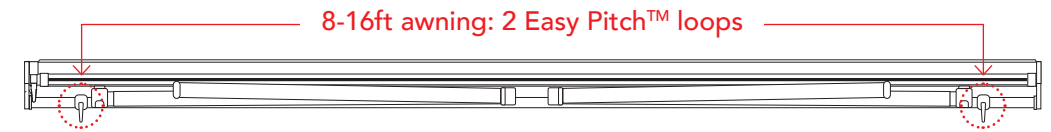

Fig 34

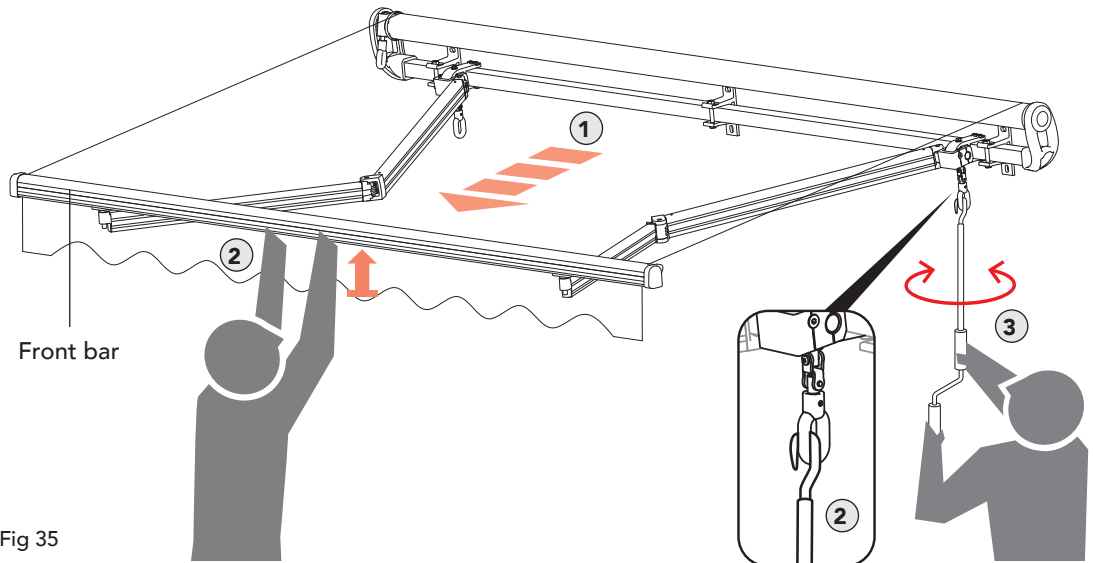

Fig 35

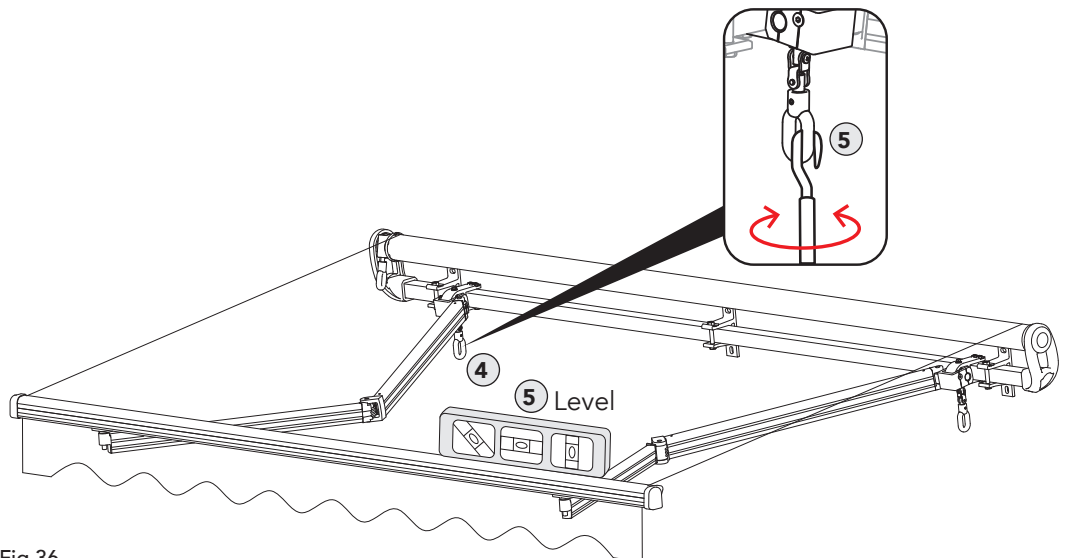

Fig 36

MAINTENANCE

PREPARING YOUR AWNING FOR INCLEMENT WEATHER

Always retract and your awning closed whenever inclement weather is in the forecast to prevent damage from accumulated water, snow or from strong gusts of winds. For more detailed information regarding wind, please view our wind guide via www.advaning.com

GENERAL CARE

- A. Keep the awning fully close when not in use and at night to help maintain fabric appearance and avoid any weather related damage.
- B. Protect the awning and frame with a soft cover during prolonged periods of non-use.
- C. Lubricating your awning's moving parts once a year to prevent noises. A dry silicone lubricant or lithium grease spray is recommend. Lubrication instructions are available via www.advaning.com

CLEANING CARE

To clean your awnings fabric, lower the pitch via the Easy Pitch™ loops and open the awning to see and access the top of the fabric and for proper drainage. Use a mild soap and water mix (1 part soap to 2 parts water) and standard garden hose to gently remove any accumulated dust, dirt, or debris. Raise the pitch to its regular setting and allow the awning to fully dry before retracting/closing. To dust the awning, a damp cloth, chamois, or soft bristle brush is recommended.

PROTECTING THE FABRIC FROM MILDEW

Should the awning's fabric get wet, allow it to fully dry before retracting to prevent mildew and prolong the life of the fabric. If you must retract the awning while wet, open the awning as soon as the weather permits to allow the fabric to fully dry and remove any dirt deposits to preserve the fabric.

FRAME CARE

Perform annual maintenance on your awning such as cleaning the frame with a chamois cloth when necessary. It is important to inspect the fasteners, connections and the condition of the metal components.

WARRANTY AND CONTACTS

ADVANING 2-YEAR LIMITED MANUFACTURER'S WARRANTY FOR SLIM GRAY SERIES RETRACTABLE AWNINGS

Advaning's warranty provides coverage for all of its original Advaning Slim Gray Series awnings that are sold and installed within the United States of America and Canada to be free of defects of materials and workmanship. This warranty only applies to the original owner/purchaser of the product and is only effective on a basis of twenty four (24) months or two (2) years from the date of purchase. Any defects or issues presented to Advaning within the warranty period will be promptly handled by Advaning customer service and resolved within a reasonable timeframe.

Entire awning framework, including extruded & die cast component parts, springs & cables are covered. Should the purchaser/original owner submit a warranty claim within the warranty period Advaning will provide a resolution option that may include; new replacement parts or instructions for repair or both. Powder coated and painted finishes are excluded and are NOT covered under this limited warranty.

During the warranty period, owners in Canada, Hawaii, Alaska and Puerto Rico are covered for parts/replacements at no charge, however, the owner would assume all shipping/handling and applicable duties and taxes. Advaning's Warranty does not cover any return shipping or prepaid return labels. Should the purchaser/owner notify Advaning within the warranty period from the date of the original purchase and after deemed defective by Advaning, will the warranty claim be resolved by either of the following: A. Defective component replacement (shipping charges may apply), B. Detailed instructions for correcting the issue, Or a combination of both A and B.

WARRANTY LIMITATION AND EXCLUSION

The warranty will be in effect once the awning is fully paid for.

Advaning is not responsible for damages due to faulty modifications, installation, or re-installation.

Advaning assumes no liability for damage to the structure to which the awning is attached, or to the property located underneath the awning. This limited warranty does not cover damage from ice, snow, hail, high winds, vandalism, neglect, improper use, or any natural disasters. This limited warranty does not cover degradation due to salt corrosion, oxidation, and chipping or peeling of the paint.

Problems and Warranty Claims

If you experience a problem with your Advaning product, please contact Advaning Customer Service at service@advaning.com.

- Prior to contacting Advaning via phone or email for warranty claims, please have your model name/number, serial/lot number, original proof of purchase*, and a description of difficulty experience ready for our Customer Service team. Most issues can be resolved over the telephone by our trained Customer Service representatives. If any issues arise that cannot be solved over the phone or email, Advaning will issue a Return Merchandise Authorization ("RMA") number, and arrange replacement parts for you.
*Proof of Purchase: A valid sales/purchase receipt is required with authorized reseller/retailer name, the purchase date and the model number of the item purchased.
- Submitting a claim will not extend or alter the warranty coverage period. Any work done by a 3rd party or non-authorized person/Advaning agent will void the warranty.

THIS WARRANTY IS EXCLUSIVE AND IS IN LIEU OF ANY AND ALL OTHER WARRANTIES, EXPRESSED OR IMPLIED. NO IMPLIED WARRANTIES OF MERCHANTABILITY OR FITNESS FOR A PARTICULAR PURPOSE

WARRANTY AND CONTACTS

ARE GIVEN, ANY AND ALL LIABILITY FOR BREACH OF ANY IMPLIED WARRANTY OR WARRANTY CREATED BY LAW IS DISCLAIMED.

Some states do not allow limitations on how long an implied warranty lasts, so the above limitation may not apply to you.

UNDER NO CIRCUMSTANCES SHALL ADVANING, INCLUDING ITS SUBSIDIARIES AND AFFILIATES BE LIABLE FOR INCIDENTAL OR CONSEQUENTIAL DAMAGES WITH RESPECT TO ECONOMIC LOSS, INJURY, DEATH OR PROPERTY DAMAGE, WHETHER AS A RESULT OF BREACH OF THIS WARRANTY, NEGLIGENCE OR OTHERWISE.

Some states do not allow the exclusion or limitation of incidental or consequential damages, so the above limitation or exclusion may not apply to you in whole or in part. This warranty gives you specific legal rights. You may also have other rights that vary from state to state.

What is Not Covered by the Advaning Limited Warranty

This warranty is non-transferable and does not cover product purchases from the initial buyer to a third party. This warranty does not cover incidental damages, such as loss of time, loss of use, or installation costs of defective, repaired or replaced product. This warranty does not cover product that has been damaged or rendered defective as a result of:

- (a) Neglect, abuse or misuse.
- (b) Modification of the original product.
- (c) Improper use or installation using products not manufactured by Advaning.
- (d) Service provided by anybody other than Advaning.
- (e) Abnormal mechanical or environmental conditions.
- (f) Unusual physical or electrical stress -including failure or fluctuation of electrical power, lighting, static electricity, fire, tornadoes, or other natural disasters.

Shipping Damage Claim:

On the occasion of a damage claim caused by the shipper/shipping company, the owner must contact their point of sale and the delivering freight carrier within 3 days of signing for the delivery in order to make a claim. Failure to report freight damage and missing parts in a timely manner and in accordance to the carrier's guidelines may result in you incurring all costs. Likewise, there are 5 days from the time of delivery to report missing parts to Advaning.

For more information, please contact the corporate office.

Advancing Customer Service Center
Email: service@advaning.com

LIMITED TIME OFFER – Free, 8 Months *Extra Warranty Coverage

Register your awning purchase within 60 days of purchase along with **installation photos to receive an *Extra 8 months of warranty coverage.

www.advancing.com/warranty-registration

*parts only, shipping not included. / **submitting photos grants Advaning permission to reproduce any portion of the photo image for print, web, or any other marketing purpose including social media outlets.

CONTACT INFORMATION

Product Questions?

Please contact Advaning via email at service@advaning.com, by phone at 714-622-2600, or by chat on our website; www.advaning.com

Advaning Customer Service is available Monday through Friday from 8:30 a.m. to 4:00 p.m. PST

www.advaning.com