

# CLASSIC SERIES Retractable Awning

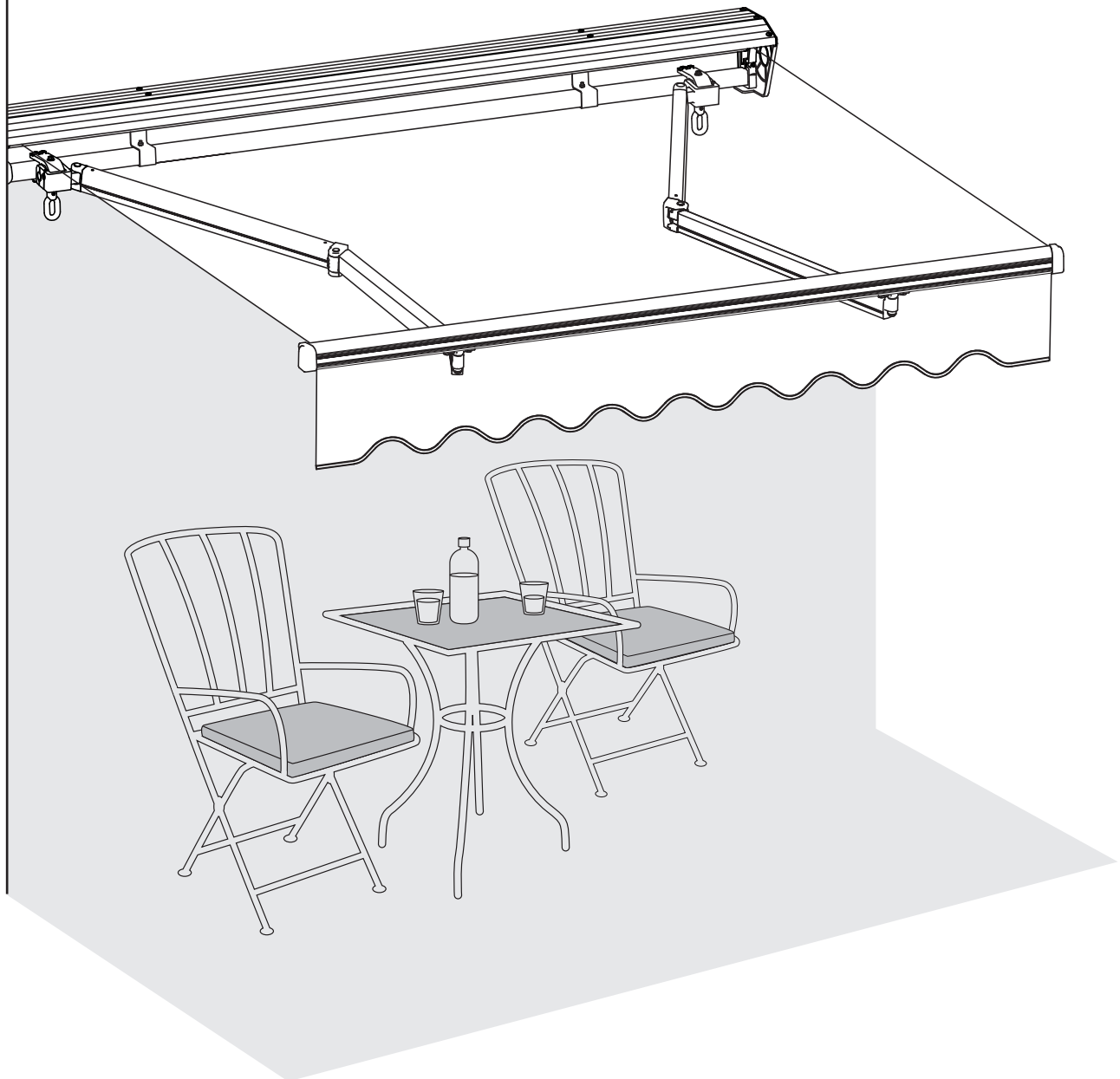

## Owner's Manual

For your safety and the safety of others, please read all of the instructions and warnings in this manual carefully before peceeding with installation and usage

# TABLE OF CONTENTS

Safety instructions and warnings . . . . .	2
Package contents and parts . . . . .	4
Tool requirements . . . . .	5
Awning terminology and location . . . . .	6
Installation	
Bracket placement reference chart . . . . .	7
Pre-Installation guide (standard) . . . . .	8
Pre-Installation guide (roof mount) . . . . .	9
Install wall brackets	
Standard stud installation . . . . .	10
Masonry installation . . . . .	12
Install ceiling/soffit brackets . . . . .	14
Install awning onto brackets . . . . .	16
Ready your awning . . . . .	16
Electric awnings, power cord connection . . . . .	17
Electric awnings, prepare your remote control . . . . .	17
Operation	
Manual operation . . . . .	17
Electric operation . . . . .	18
Fabric rolling direction . . . . .	18
Adjust awning pitch . . . . .	19
Maintenance . . . . .	20
Warranty and customer service . . . . .	21~22

# SAFETY INSTRUCTIONS AND WARNINGS



In order to avoid accidental injury or damage, **DO NOT** remove arm safety restraints until instructed.

The awning arms contain tensioned cables. Always use caution, securely tie the awnings arms to the awning when performing installation, adjustments, or repairs. Sudden movement of tension arms can result in serious personal injury, product and/or property damage.

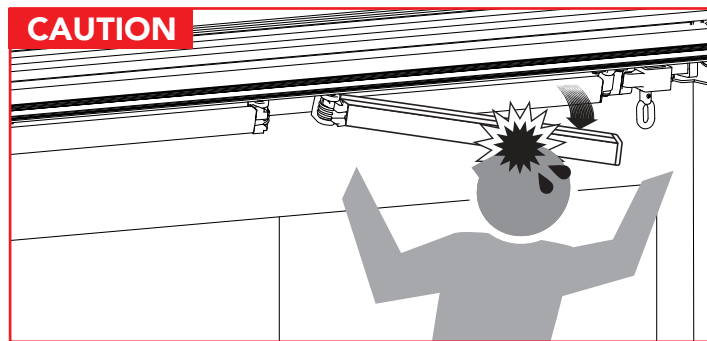
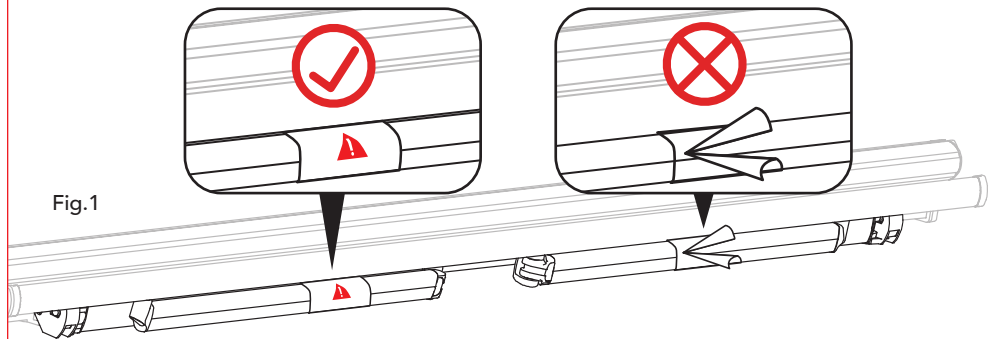

**SAFETY FIRST, PLEASE READ THE FOLLOWING POINTS TO REDUCE THE RISK OF FIRE, ELECTRIC SHOCK OR PERSONAL INJURY.**

## Installation

- Pay close attention throughout the installation process to ensure that the Advaning awning is installed properly and according to the safety guidelines outlined herein.
- Do not attempt installation while under the influence of alcohol or drug substances.
- Do not remove the safety restraints from the awning's lateral arms until instructed to do so. The arms contain tensioned springs and may release very quickly. Always ensure no persons or objects are directly in arm projection path at all times.
- Do not proceed with an installation if you feel that you cannot properly and safely complete, please seek professional help.
- Always wear protective gear and gloves when handling sharp metal parts.
- Only perform installation/maintenance/cleaning in dry and optimal weather conditions.
- 2 or more persons are recommended for installation. Installation will require to lift the assembled awning onto the brackets. Ensure help is available to help lift.

# SAFETY INSTRUCTIONS AND WARNINGS

## Usage

- Only use Advaning recommended accessories and original replacement parts.
- Only perform installation/maintenance/cleaning in dry and optimal weather conditions.
- Do not place any heat source or open flame under or near the awning.
- Do not place, hang, or stand objects or persons on the awning itself. Doing so can damage the awning or cause severe personal injury and in extreme cases death.
- Do not carry out any maintenance other than what is shown in this manual. For any issues that are not covered in this manual, please seek support from Advaning Customer Service. Email: [service@advaning.com](mailto:service@advaning.com)
- The product should only be operated by an adult that understands all the functions and operations. Please keep unsupervised children away from playing with the awning or its parts.
- The product should be used only as described in this Advaning Owner's manual.

## Electric Awnings Only

- Do not disassemble the awning motor, please seek support from Advaning Customer Service. Email: [service@advaning.com](mailto:service@advaning.com).
- Do not handle any part of the power plug or motor with wet hands or objects. Doing so could induce an electric shock.
- Do not use the electric option if the cord or plug is damaged. For damaged power cords and plugs, please seek support from Advaning Customer Service. Email: [service@advaning.com](mailto:service@advaning.com)
- Ensure that the power cord is not strained and that it has ample slack to avoid damage. Avoid pulling the cord around sharp edges or corners. Keep the power cord away from high traffic areas.
- Do not pull or tug on the cord. Grasp the plug by the base when unplugging the device to avoid damage. Rewind the cord and store to prevent a tripping hazard.

**DO NOT** keep the awning open during:

A: RAIN

B: SNOW

C: STRONG WIND

D: UNSUPERVISED PERIODS

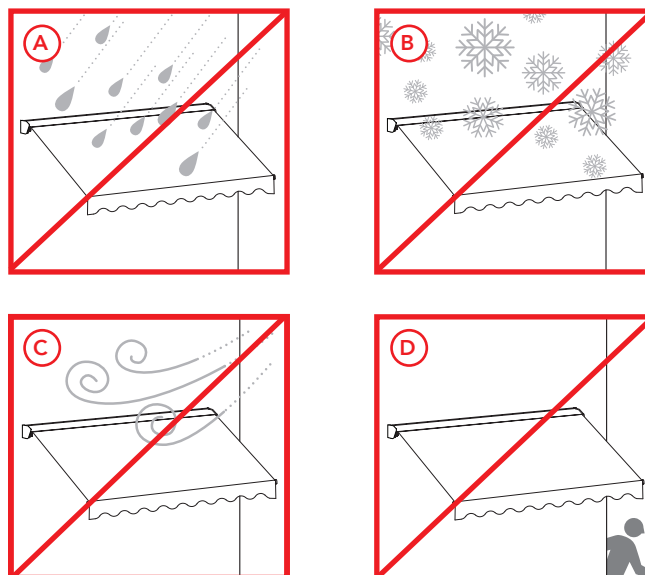

Fig.3

# PACKAGE CONTENTS AND PARTS

Before attempting your install, please ensure that the package contains all parts and qty's as listed for your awning size.

\*Motorized models Include:

- 16ft power cord
- Motor Regulator
- Remote Control Kit
  - Remote with cover screw
  - Battery
  - Wall Cradle
  - Wall Mount with screws

Advaning's motorized awnings allow users to set a custom stop setting with the Motor Regulator tool.

To safeguard your awnings warranty, we ask that you contact Advaning's customer support for proper instructions before attempting any adjustments. Adjustments without safeguarding your warranty first voids the motors warranty.

If no custom settings are needed, please save the Motor Regulator tool with your Owner's Manual in case it is needed in the future.

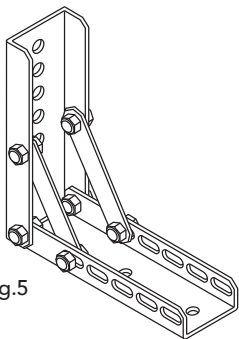
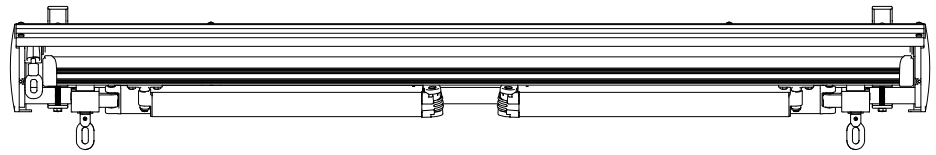

Fig.5

**Optional Roof Mount Brackets ~ Sold Separately**  
Part# ZAW-RM-BRK



Assembled Awning Qty: 1



Hand Crank Qty: 1 (63 Inches Length)



Motor Regulator\* Qty: 1

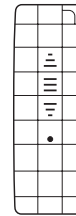

Remote Control Kit\* Qty: 1

Fig.4

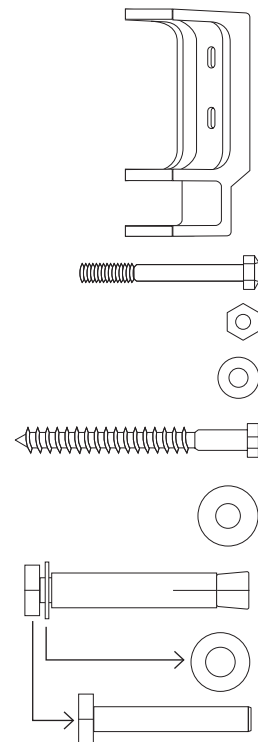

Fig.6

Model Size		8'~10'	12'~16'
Parts name		Quantity	
Wall/ceiling dual bracket set	Wall/ceiling bracket	2	3
	Retaining hex bolt	2	3
	Retaining nut	2	3
	3/8" washer	2	3
3/8" x 4" Lag screw		4	6
3/8" Flat washer		4	6
M13 x 3" Expansion Bolt	Expansion bolt	4	6
	Washer	4	6
	Hex bolt	4	6

# TOOL REQUIREMENTS



Minimum 2 people to install

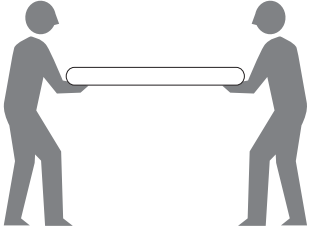

## REQUIRED TOOLS

- ① Marker / pencil
- ② Measuring tape
- ③ Electronic Stud finder
- ④ Chalk line / laser level
- ⑤ Level
- ⑥ 3/8" socket wrench
- ⑦ \*Wood Drill Bit
- ⑧ 1/2" Masonry Drill Bit  
Power Drill / Hammer
- ⑨ Drill (Masonry)
- ⑩ Ladders (2)

\*Dependent on wood species:  
1/4" ~ 9/32" drill bit.

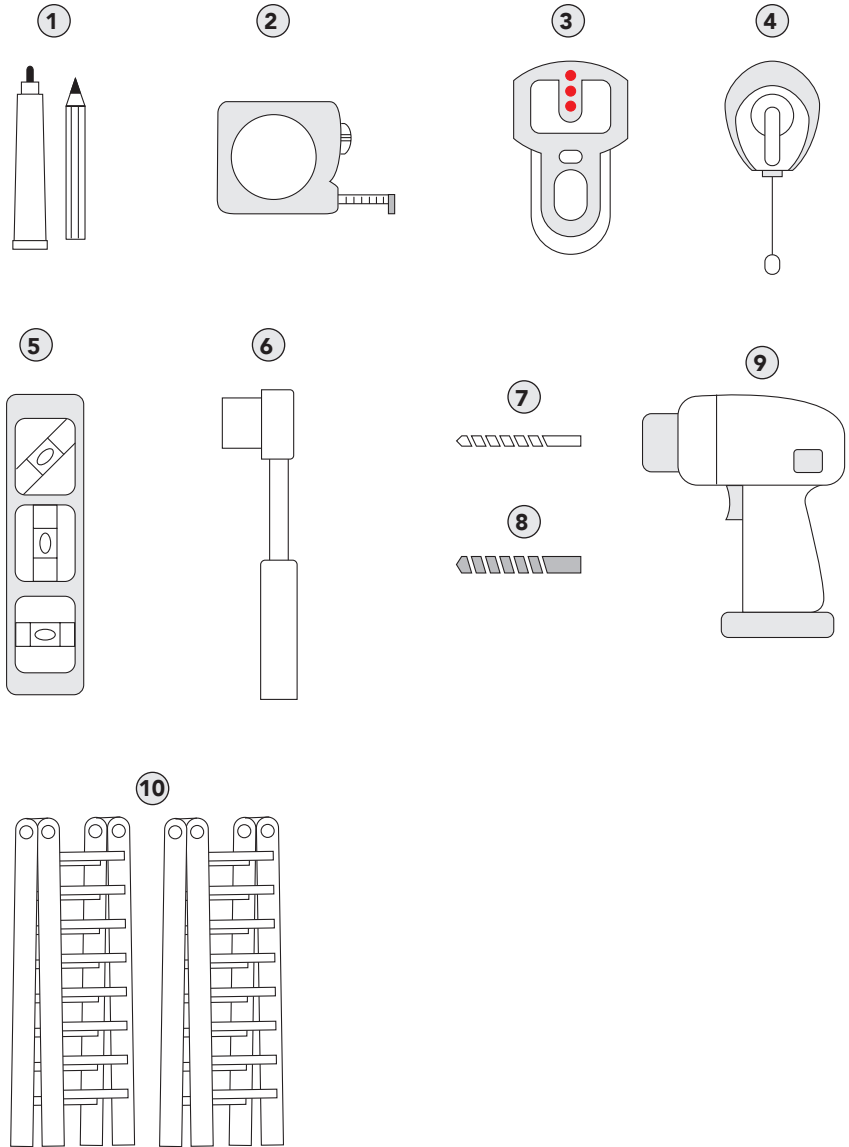

Fig.7

# AWNING TERMINOLOGY AND LOCATION

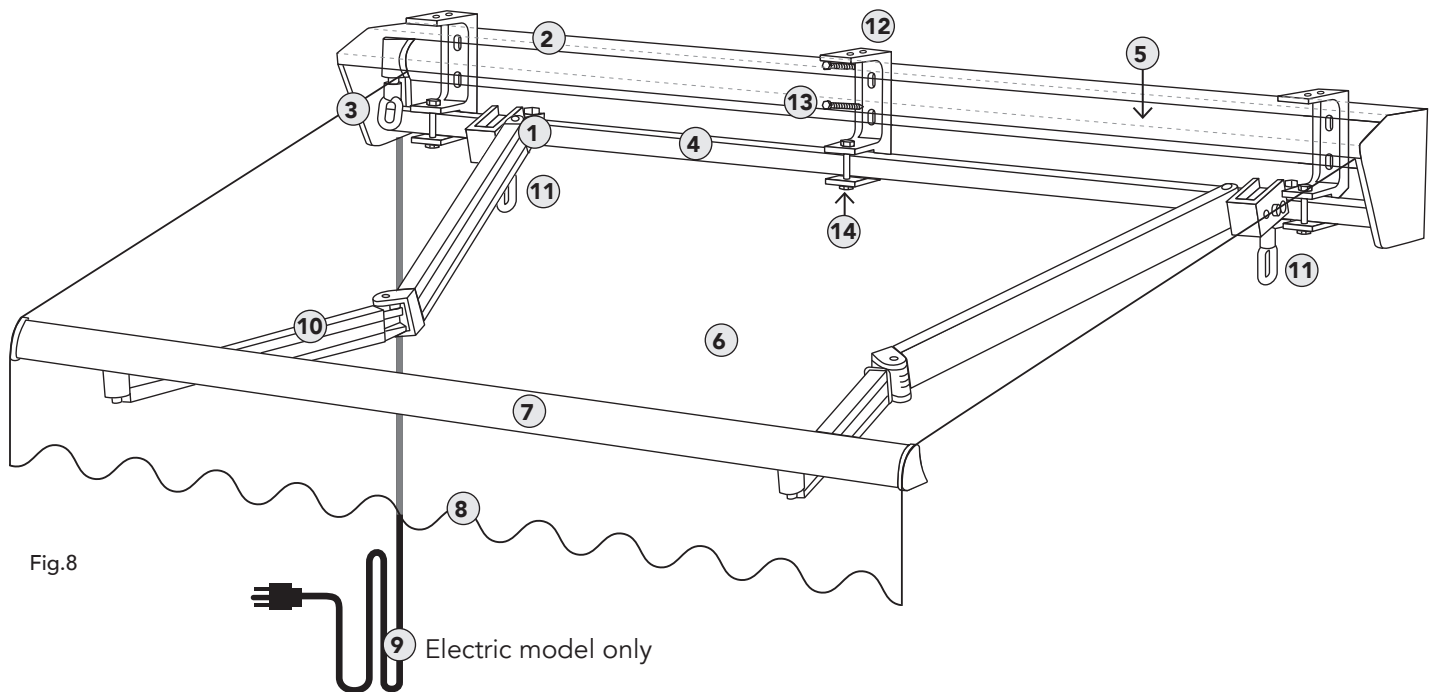

Fig.8

- ① Arm shoulder
- ② Cassette
- ③ Crank loop
- ④ Torsion bar
- ⑤ Roller tube
- ⑥ Awning fabric
- ⑦ Front bar
- ⑧ Valance
- ⑨ Powercord
- ⑩ Retractable arms
- ⑪ Easy Pitch™ loop
- ⑫ Wall/ceiling bracket
- ⑬ Lag screw
- ⑭ Retaining bolt

# INSTALLATION

## BRACKET PLACEMENT REFERENCE CHART

Use the illustrations below for optimal bracket placement.

- Ⓐ Left awning shoulder
- Ⓑ Right awning shoulder

## IMPORTANT

**ALL BRACKETS MUST BE MOUNTED DIRECTLY ONTO WALL STUDS OR OTHER MAJOR STRUCTURAL SUPPORTS.**

FOR OPTIMAL BALANCE OF THE AWNING WEIGHT DISTRIBUTION, PLEASE ATTEMPT TO FOLLOW THE BRACKET PLACEMENT AS ILLUSTRATED.

**NOTE:** NOT EVERY INSTALLATION IS IDENTICAL AND MOST STUDS/STRUCTURAL SUPPORTS WILL NOT ALWAYS ALIGN, THE BRACKETS MAY BE MOVED TO BEST SAFELY FIT YOUR SPECIFIC STUD/STRUCTURAL SUPPORT LOCATION WHILE SUPPORTING THE AWNING ONCE INSTALLED.

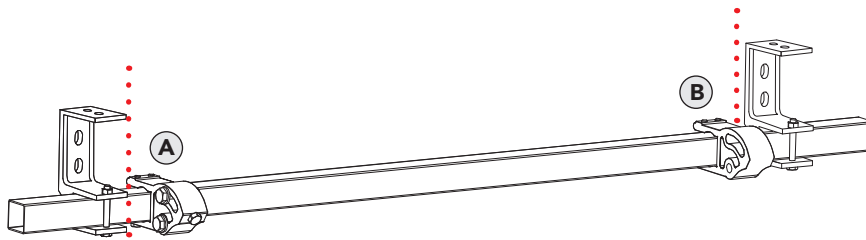

8 ~ 10 feet awning

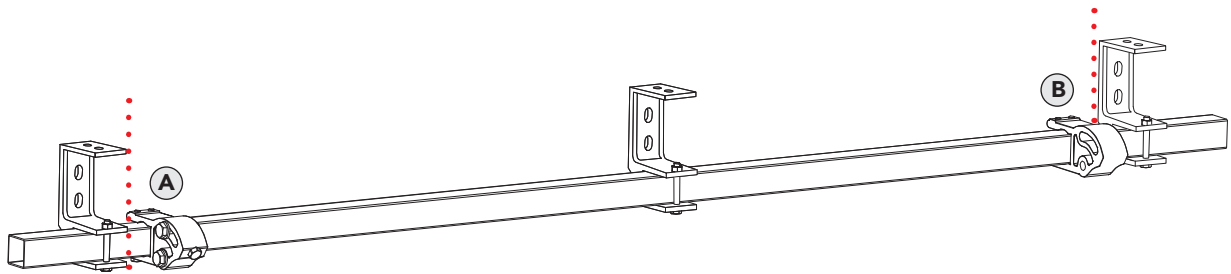

12-16 feet awning

Fig.9



# INSTALLATION

## PRE-INSTALLATION GUIDE (STANDARD)

Locate a position that is

- Ⓐ Recommended: 8 to 10 ft. above the ground/floor, deck etc.
- Ⓑ Recommended (for wall mounts only): Minimum of 1 inch clearance below the roof/eave/overhang etc.
- Ⓒ Critical: Minimum of 10 inches clear vertical run length (no obstructions) – depending on awning size.



Run length should be free and clear of any obstructions along the entirety of planned install site.

Personal & specific structural physicalities may require deviation from the recommended measurements, consult with a professional installer who can best assess your installation site and ensure a safe and full function of the awning once installed.

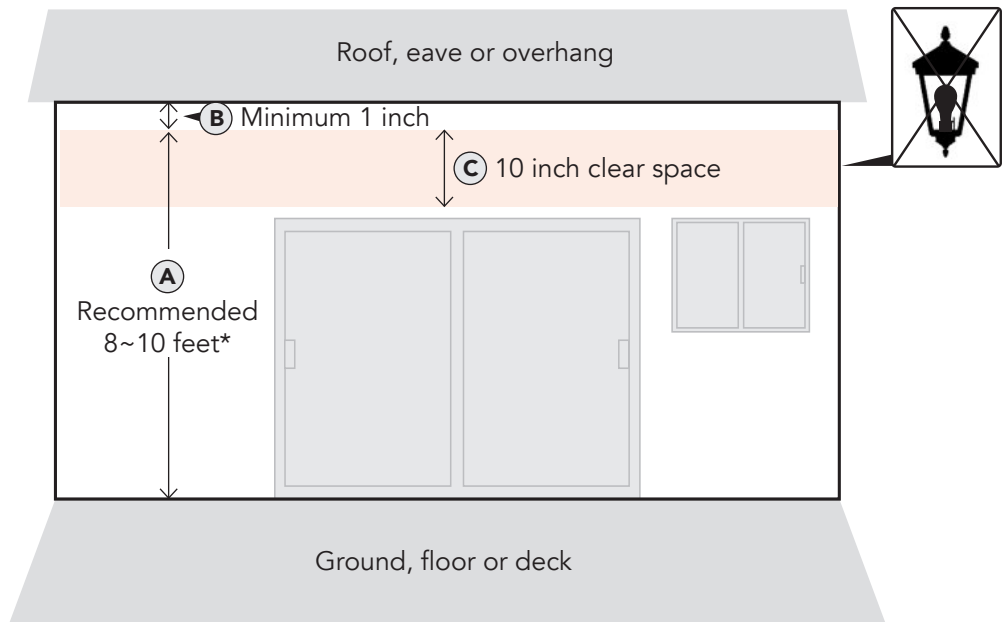

Fig 10

### Side view

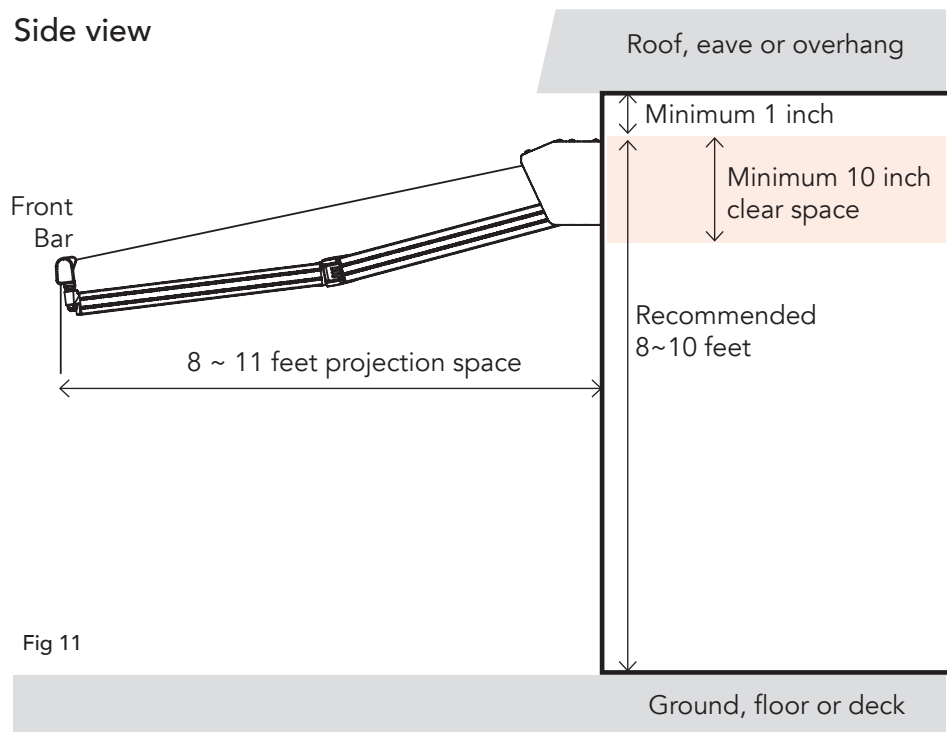

Fig 11

# INSTALLATION

## PRE-INSTALLATION GUIDE (ROOF MOUNT)

Locate a placement on roof that is:

- Ⓐ Straight/Level Roof Line - Parallel to Level Ground.
- Ⓑ Clear of Any Obstructions for a Minimum of 12 inches.
- Ⓒ Has a Continuous Line of Roof Rafters.

Ensure the spacing allows for the run length of your awning.

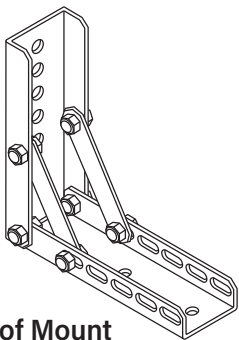

**Roof Mount**  
Sold Separately

**IMPORTANT!** Ensure that you have the sufficient quantity of roof brackets before proceeding with your installation.

All Roof Mount Brackets must be mounted directly to roof rafters or other major structural supports.

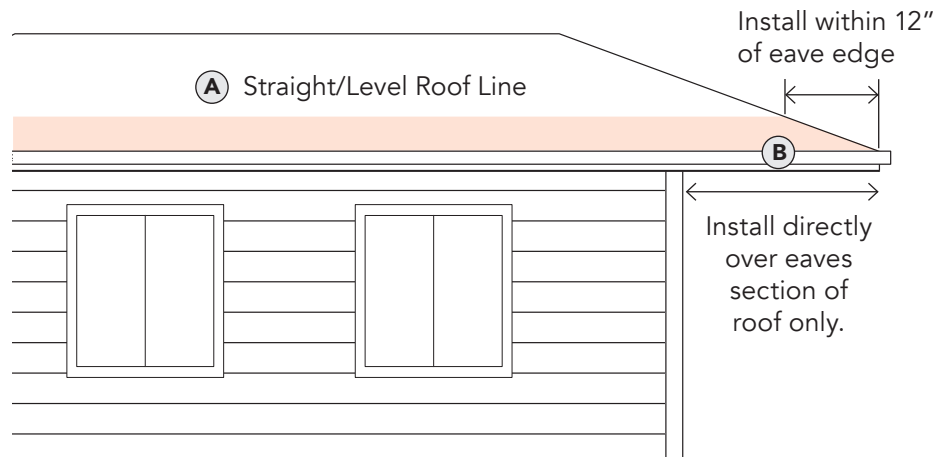
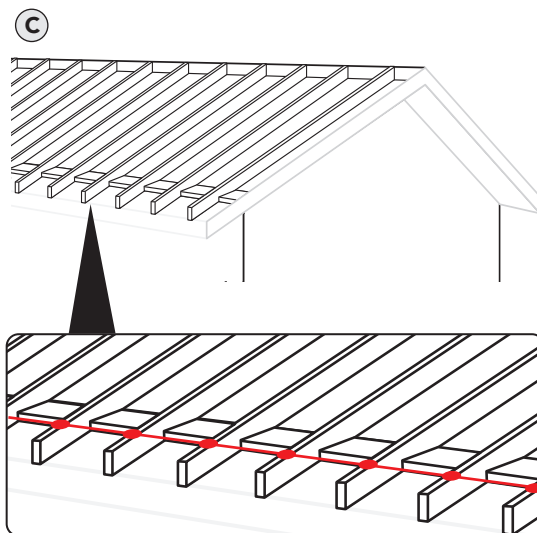
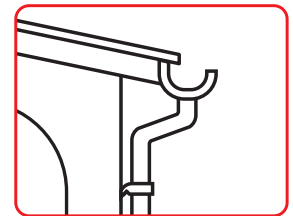

Fig.12



Install directly onto roof rafter.

Fig.13



### **CAUTION**

Gutters may obstruct access to Awning's Open/Close & Tilt Functions

# INSTALLATION

## WALL MOUNT INSTALLATION

### General stud framing installation

- ① Measure and mark where the top of your awning bracket will be placed.
- ② Use a level and chalk line or laser level to mark your bracket guide line.
- ③ Locate and mark the center of the wall studs along this line using a stud finder. \*Follow your specific stud finders manufacturer's instructions to properly locate studs.
- ④ Align the top of the bracket to the chalk line.
- ⑤ Align the center of the bracket mounting holes with the center of the stud.

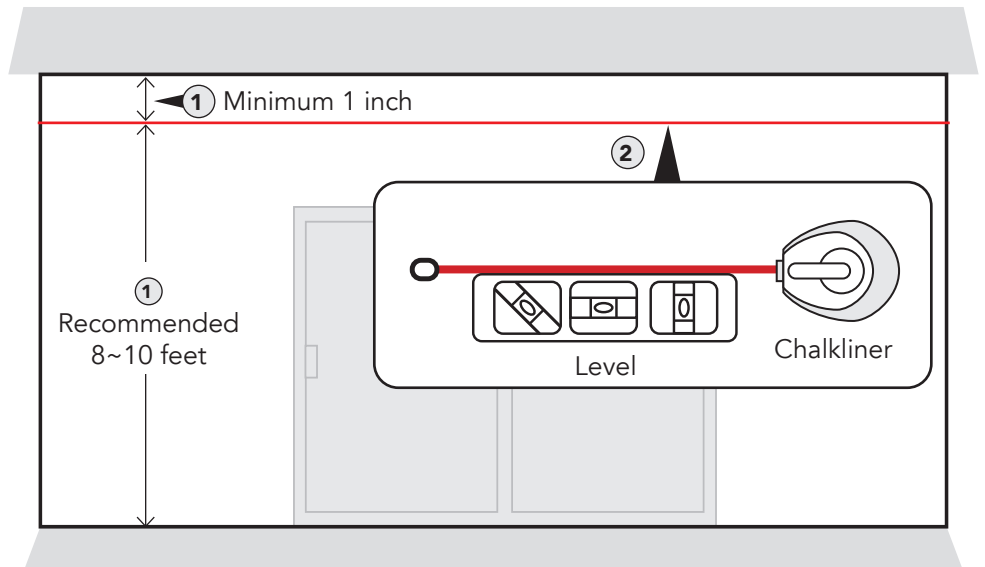

Fig 14

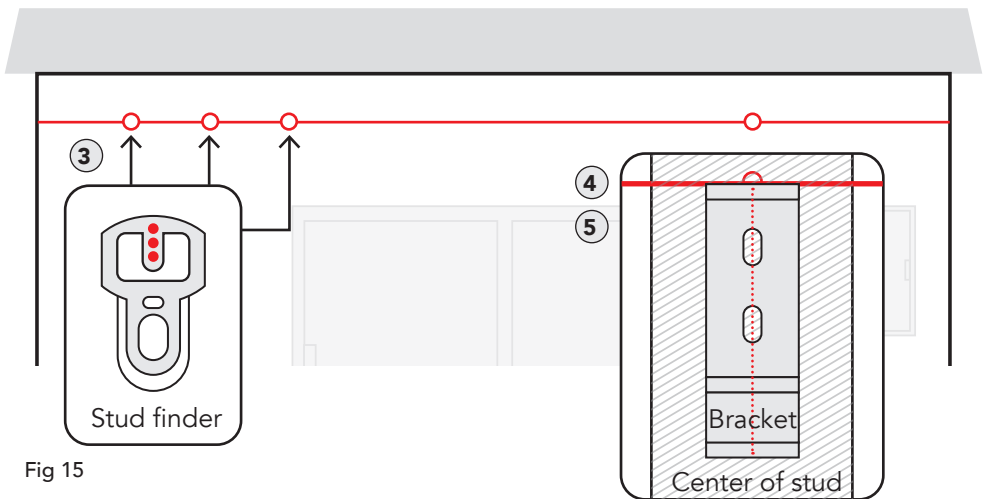

Fig 15

# INSTALLATION

- ⑥ Use a level to make sure the bracket is straight and mark the center of the mounting holes.
- ⑦ Drill mounting pilot holes.
- ⑧ Place bracket over pre-drilled holes and use a level to ensure the bracket is leveled and square to line.
- ⑨ Use a lag screw and washer to secure the bracket to your wall/surface, repeat for each bracket.

For proper installation of brackets on uneven surfaces or siding, use shims or spacers to level the bracket.

Due to a variety of siding finishes/materials, Advaning recommends contacting the siding manufacture for necessary requirements before using shims, cutting or drilling into your siding.

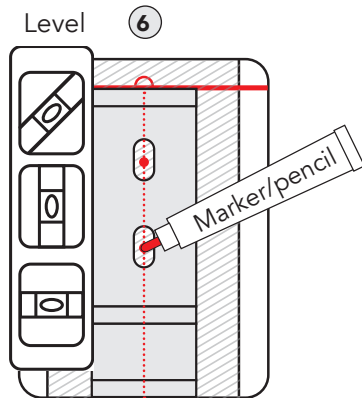

Fig 16

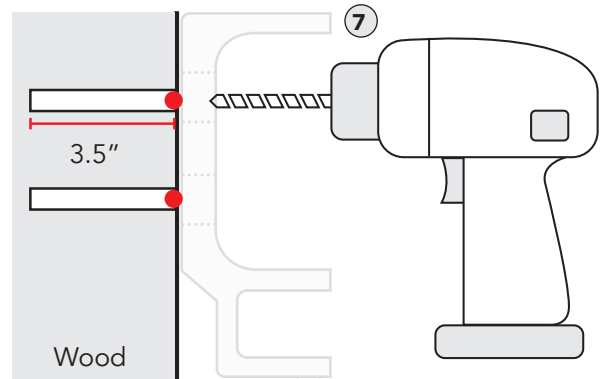

Fig 17

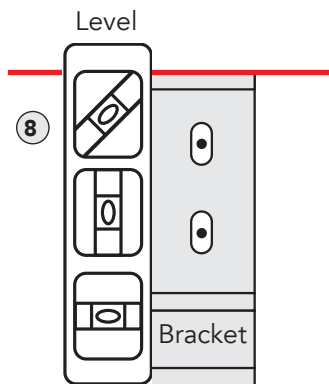

Fig 18

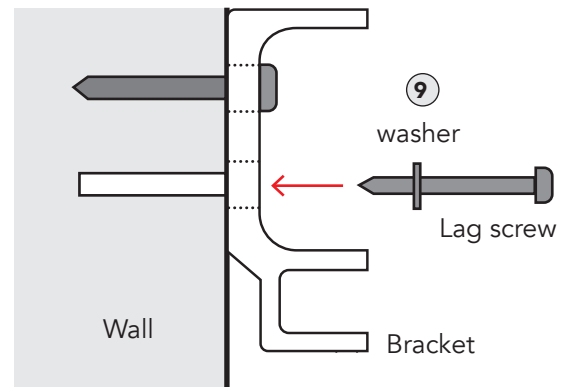

Fig 19

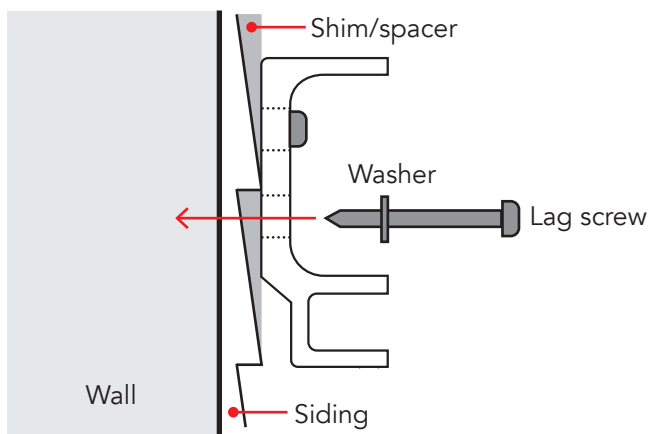

Fig 20

# INSTALLATION

## Masonry Installation

General (solid) masonry installation

**CAUTION:** Brackets must be installed directly onto solid brick or concrete.

Avoid severe personal injury & property damage - Never install brackets to grout, mortar or hollow masonry substrates

Masonry Installation detailed photos and tips available via [www.advaning.com](http://www.advaning.com)

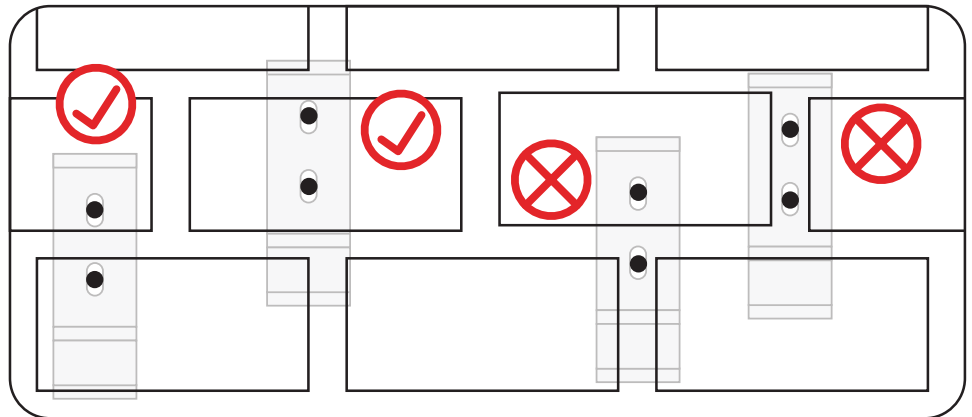

Fig 21

① Follow instructions for standard installation step 1 and 2 (page 7).

② Use the recommended bracket location chart (page 5) to find bracket location for your awning model along the line.

③ Align the top of the bracket to the chalk line and use a level to make sure the bracket is straight.

④ Mark the center of the bracket mounting holes.

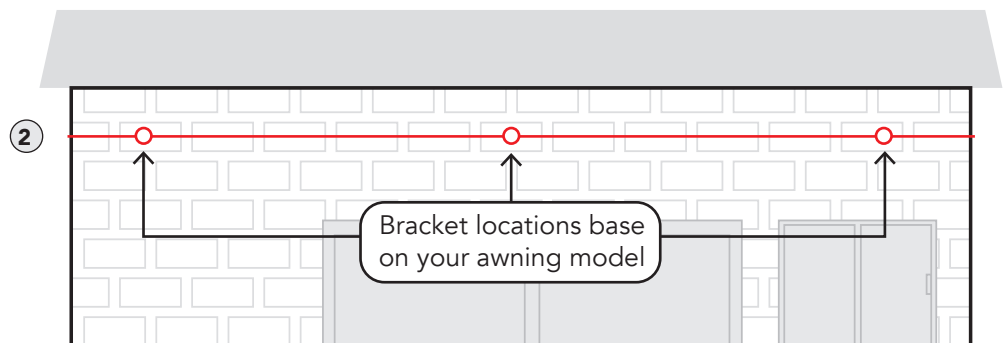

Fig 22

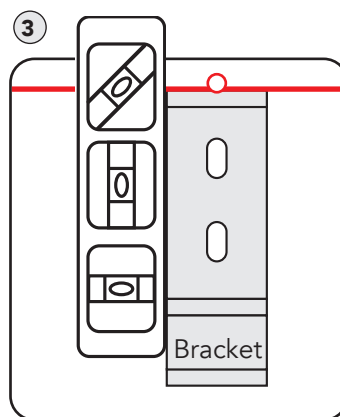

Fig 23

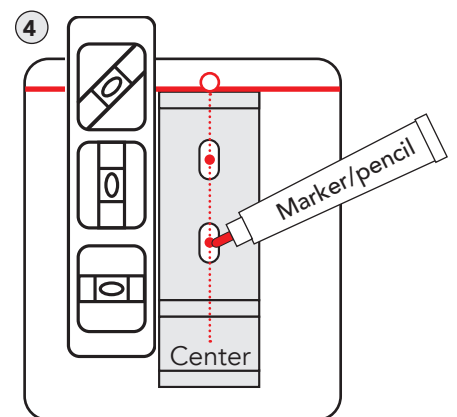

Fig 24

# INSTALLATION

- ⑤ Drill mounting pilot holes.
- ⑥ Clean the pilot hole and remove excess dust/debris with a vacuum. Insert an expansion bolt set into each hole (a hammer may be used).
- ⑦ Leave the hex bolt head outside of the hole.
- ⑧ Using a socket wrench tighten the hex bolt, this will cause the anchor/wedge to expand and lock the sleeve in place.
- ⑨ Unscrew and remove the hex bolt. Ensuring the sleeve and anchor/wedge are locked within the wall.
- ⑩ Place the wall bracket over the holes and use a level to make sure the bracket is straight.

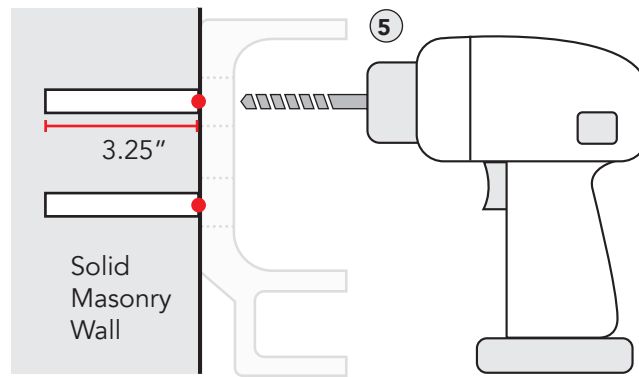

Fig 25

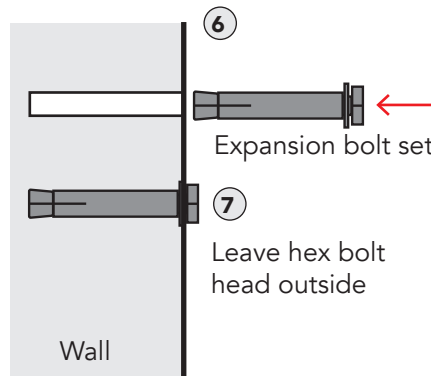

Fig 26

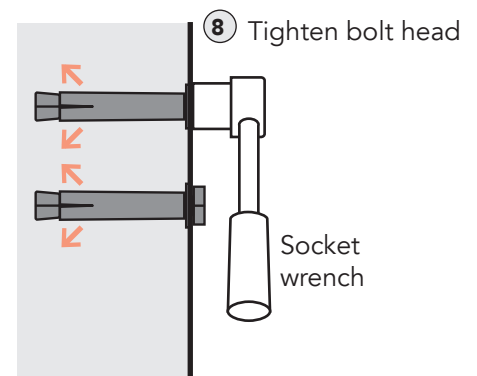

Fig 27

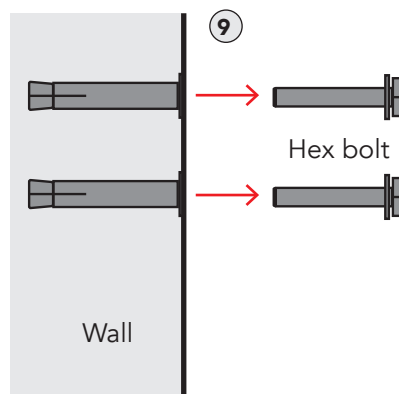

Fig 28

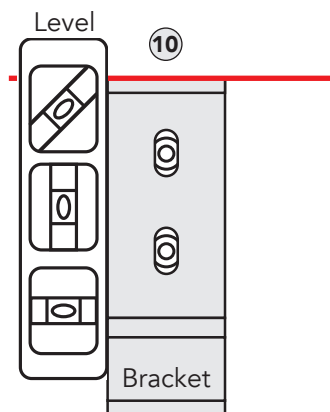

Fig 29

# INSTALLATION

- ⑪ Re-insert the hex bolt with washer through bracket and into the fixed sleeve.
- ⑫ Tighten the hex bolts to secure wall bracket to surface.

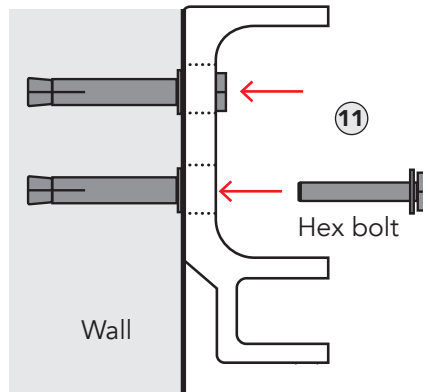

Fig 30

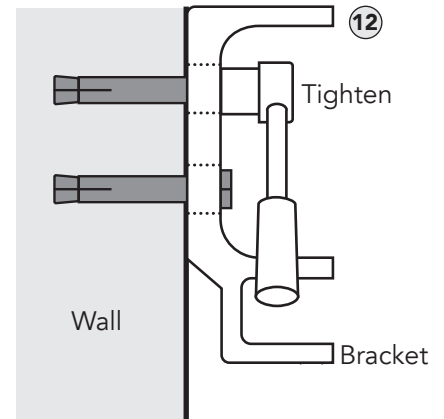

Fig 31

Masonry Installation detailed photos and tips available via [www.advaning.com](http://www.advaning.com)

## SOFFIT/CEILING INSTALLATION

General wood framing  
installation

- ① Locate a main structural support (ex: stud/truss), straight flat and leveled edge of your roof, eave or overhang that is clear and free of obstructions.
- ② Using a chalk line or laser level, mark a line that runs the entire length of your awning. The awning will stand 10" off of this line.
- ③ Use the recommended bracket location chart (page 5) to determine bracket locations for your awning model along the line.

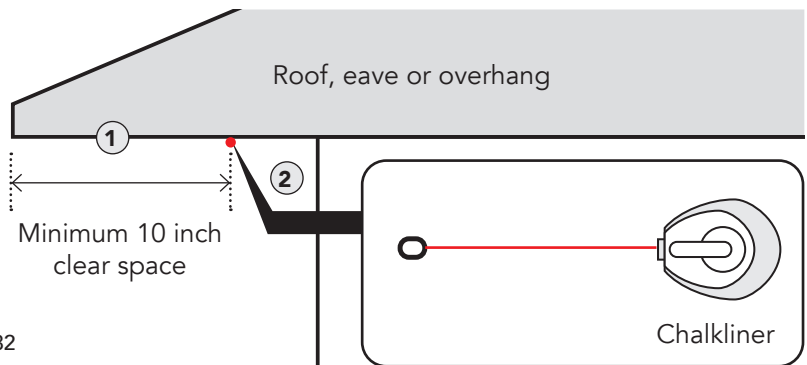

Fig 32

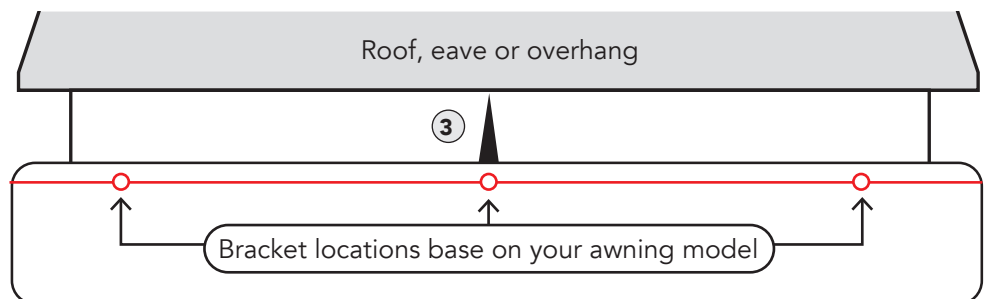

Fig 33

# INSTALLATION

- ④ Place the soffit/ceiling mount side of bracket in place, use a level to ensure bracket is straight and mark the center of the mounting holes.
- ⑤ Drill mounting holes.
- ⑥ Place bracket over the pre-drilled holes and use a level to ensure the bracket is square to line.
- ⑦ Use a lag screw and washer to secure the bracket to your soffit/ceiling, repeat for each bracket.

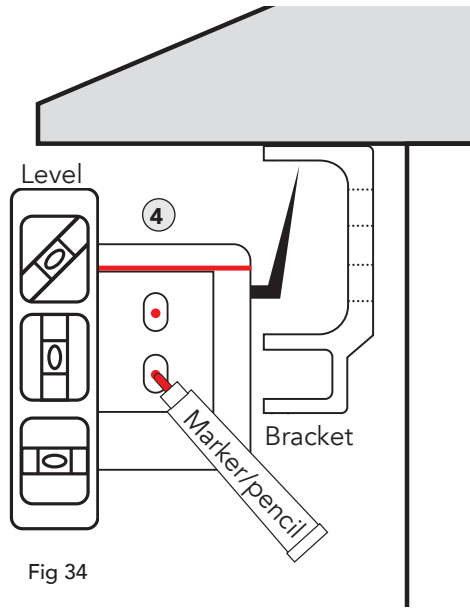

Fig 34

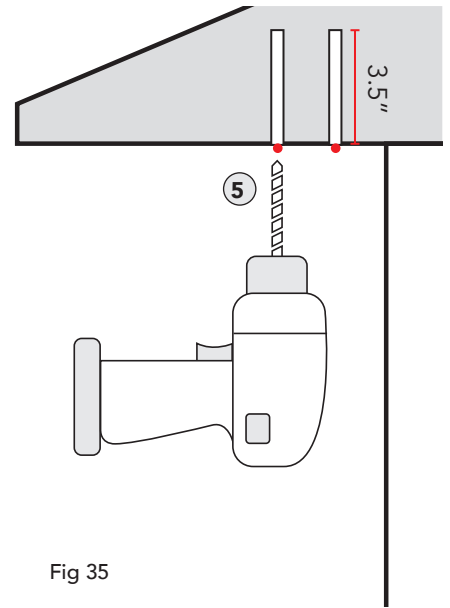

Fig 35

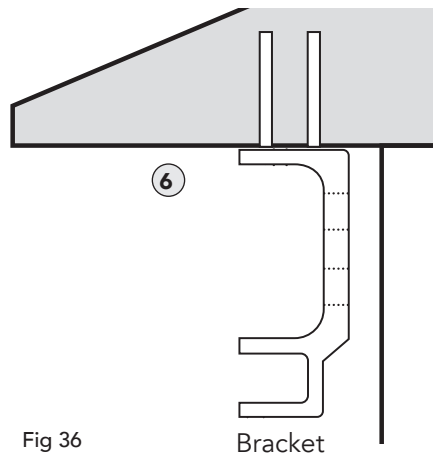

Fig 36

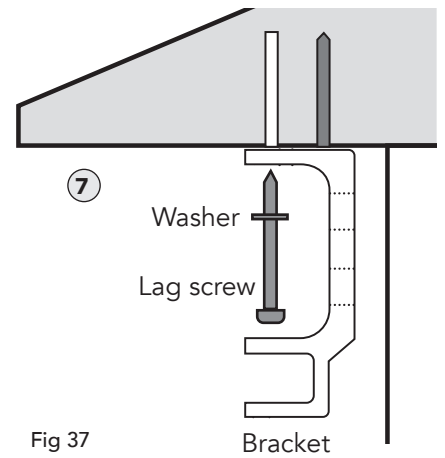

Fig 37



# INSTALLATION

## INSTALLING AWNING ONTO BRACKETS

- 1 Remove the retaining bolts from each bracket.
- 2 Lift and slide the awning to brackets and slide the torsion bar into the bracket fork.
- 3 Insert the retaining bolt and washer into the bracket fork holes and secure with nut.
- 4 Securely tighten the bolts with a socket wrench.

Fig 38

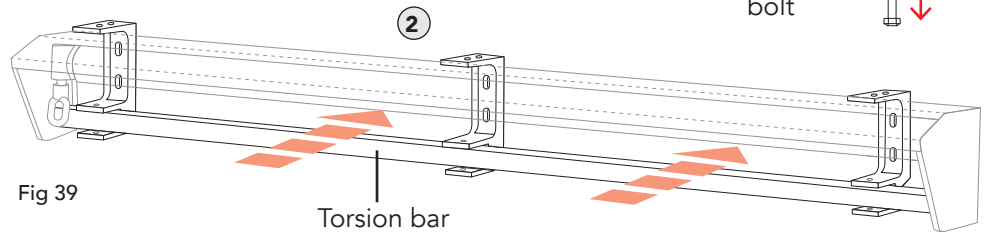
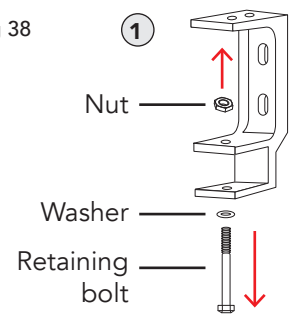

Fig 39

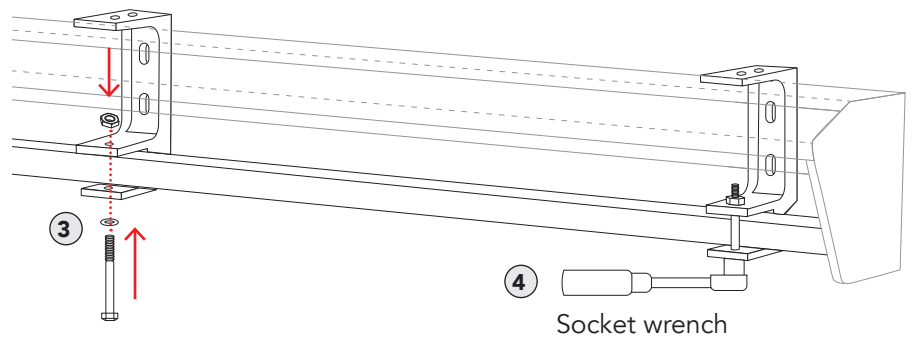

Fig 41

## READY YOUR AWNING

Before removing the safety restraints, make sure that no persons or objects are directly in arm projection path.

Motorized Awning: Do not plug in the power cord at this step.

**CAUTION:** The arms contain tensioned springs and may release very quickly.

- 1 Position yourself under the awning.
- 2 With scissors, carefully cut the safety restraints from the arms one at a time. Avoid damaging your awning – Do not use a knife or blade.

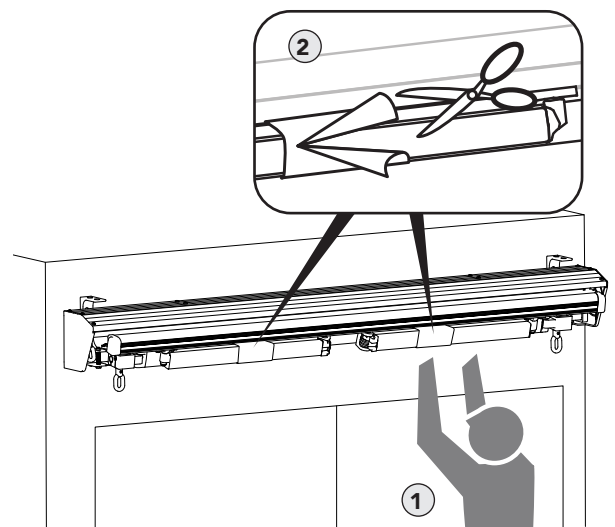

Fig 41

# INSTALLATION

## ELECTRIC AWNINGS

### Power cord connection

**Note:** Never modify the cord or plug.

- 1 Plug into a GFI rated outdoor socket.
- 2 Use a drip loop to avoid water collecting on electrical socket.

Fig 42

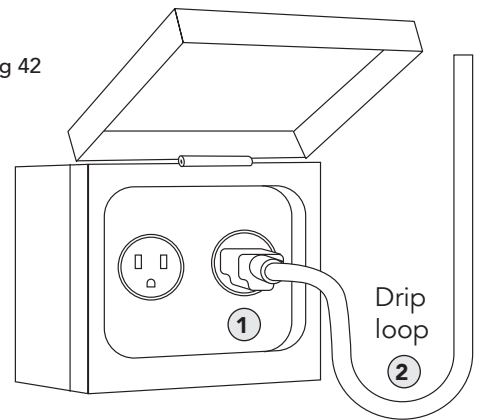

## PREPARE REMOTE CONTROL

Your remote awning will come with a CR2430 battery.

**Note:** Additional re-mote information in Maintenance Section, Page 16

- 1 Ensure the batteries (+) symbol faces out-ward.
- 2 Replace the battery cover and secure with screw.

Fig 43

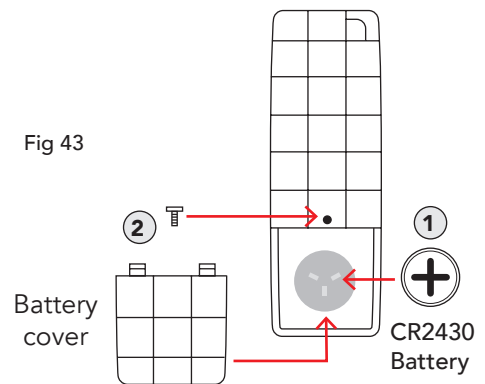

# OPERATION

## MANUAL OPERATION

- 1 Use the hand crank to open the awning fully then close it completely to test for proper operation.

**Correct rolling instructions:** Page 15, Fig 41.

- 2 Use the hand crank and open the awning to desired extension.

To keep the fabric taut, always reserve a small portion of the awning fabric on the roller tube

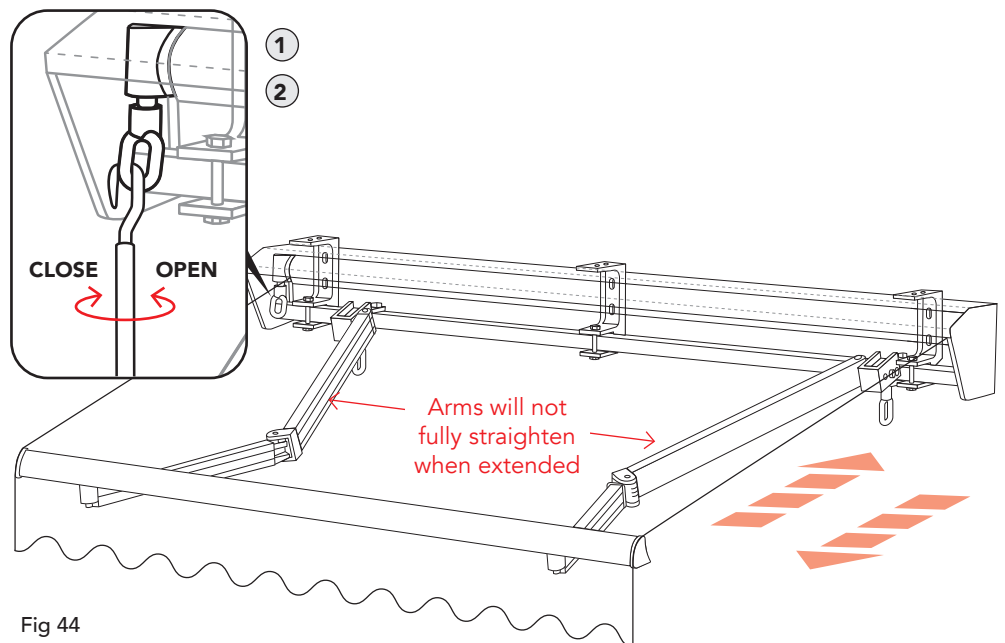

# OPERATION

## REMOTE CONTROL OPERATION – MOTORIZED AWNINGS ONLY

① Use the remote control to deploy (open) the awning fully then use the remote control to retract (close) the awning completely.

Use the remote control's  
② stop button (center) to stop the awning at a desired extension.

**Note:** Additional remote information in Maintenance Section, Page 16

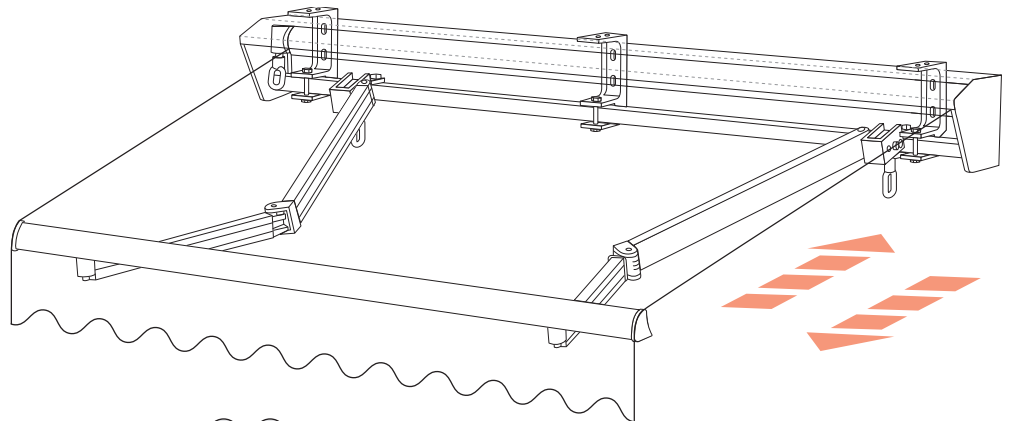

① ②

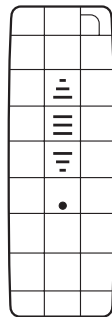

Remote control

Fig 45

## FABRIC ROLLING DIRECTION

Always ensure the fabric is rolled over the fabric roller tube.

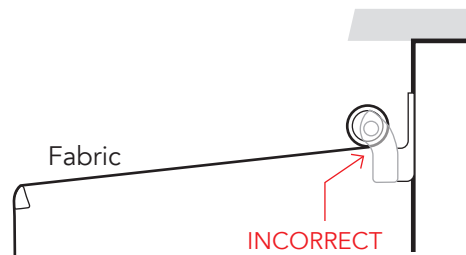
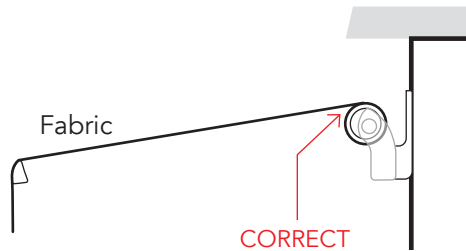

Fig 46

# OPERATION

## ADJUST AWNING PITCH

**Note:** If pitch is adjusted upwards above the factory setting of 15 degrees, we recommend lowering the pitch down to properly close the awning.

- 1 Open the awning about 1/3 extension or 2ft out.
- 2 With the aid of a helper supporting the front bar of the awning, hook the hand crank through one of the Easy Pitch™ loops.
- 3 Turn the hand crank to adjust the awnings pitch up or down.
- 4 Repeat the adjustment to all Easy Pitch™ loops.
- 5 Fully open the awning and with the use of a level ensure the front bar is straight and leveled.

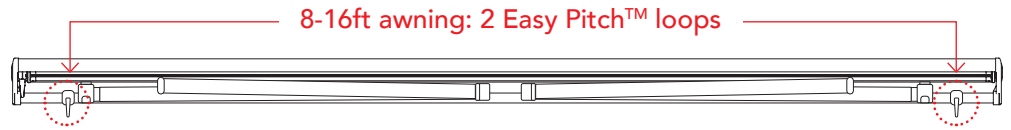

Fig 47

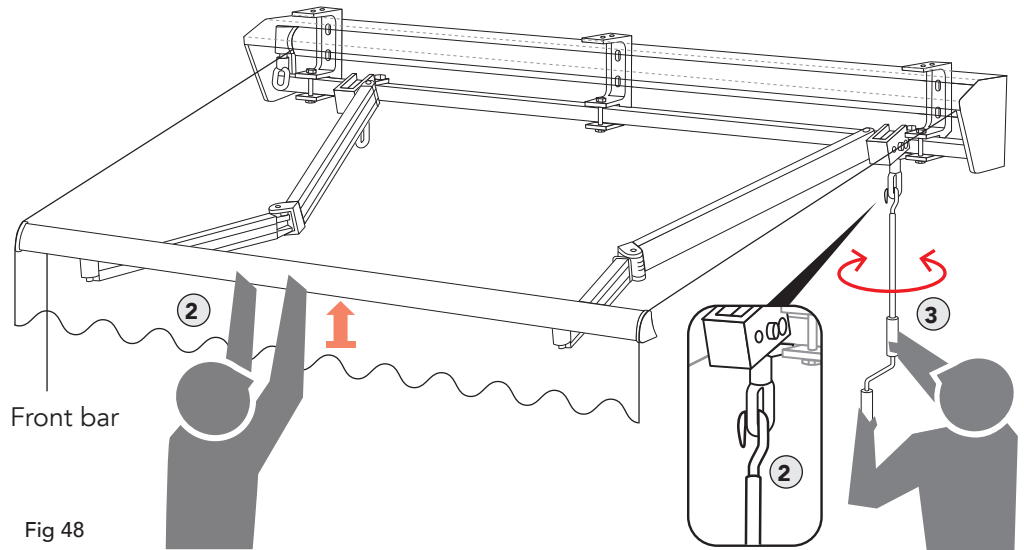

Fig 48

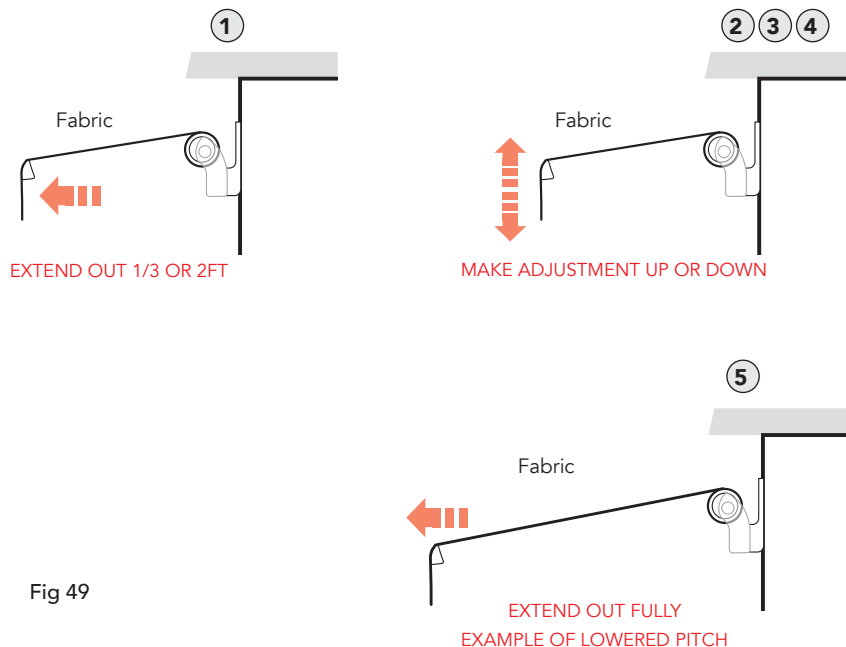

Fig 49

# MAINTENANCE

## PREPARING YOUR AWNING FOR INCLEMENT WEATHER

Always retract and your awning closed whenever inclement weather is in the forecast to prevent damage from accumulated water, snow or from strong gusts of winds. For more detailed information regarding wind, please view our wind guide via [www.advaning.com](http://www.advaning.com)

## GENERAL CARE

- A. Keep the awning fully close when not in use and at night to help maintain fabric appearance and avoid any weather related damage.
- B. Protect the awnings cassette with a soft cover during prolonged periods of non-use.
- C. Lubricating your awning's moving parts once a year to prevent noises. A dry silicone lubricant or lithium grease spray is recommend. Lubrication instructions are available via [www.advaning.com](http://www.advaning.com)

## CLEANING CARE

To clean your awnings fabric, lower the pitch via the Easy Pitch™ loops and open the awning to see and access the top of the fabric and for proper drainage. Use a mild soap and water mix (1 part soap to 2 parts water) and standard garden hose to gently remove any accumulated dust, dirt, or debris. Raise the pitch to its regular setting and allow the awning to fully dry before retracting/closing. To dust the awning, a damp cloth, chamois, or soft bristle brush is recommended.

## PROTECTING THE FABRIC FROM MILDEW

Should the awning's fabric get wet, allow it to fully dry before retracting to prevent mildew and prolong the life of the fabric. If you must retract the awning while wet, open the awning as soon as the weather permits to allow the fabric to fully dry and remove any dirt deposits to preserve the fabric.

## FRAME CARE

Perform annual maintenance on your awning such as cleaning the frame with a chamois cloth when necessary. It is important to inspect the fasteners, connections and the condition of the metal components.

## MOTOR NOTICE

The electric motor is equipped with an automatic overheat protection shutoff system. If you run your awning several times continuously, the motor will stop its operation. It will resume normal operation after 30 minutes.

Do not attempt to disassemble or modify the motor. Should your motor not operate correctly, please close your awning manually and contact Advaning Customer Service. Email: [service@advaning.com](mailto:service@advaning.com)

## MOTOR CARE

To prevent water from entering the power outlet and damaging the motor, form a drip loop as shown in figure 37. The bottom of the loop is lower than the power outlet to prevent water from pooling near the electrical socket and power plug.

## REMOTE CARE

Your remote uses a CR2430 battery, this battery may be replaced as needed. Always ensure that the battery is properly clipped in place + symbol facing out and cap secured with screw. In the case of remote malfunction you may need to re-synch your remote, please contact [service@advaning.com](mailto:service@advaning.com) for detailed step by step instructions.

# WARRANTY AND CUSTOMER SERVICE

## **ADVANING 3-YEAR LIMITED MANUFACTURER'S WARRANTY FOR CLASSIC SERIES RETRACTABLE AWNINGS**

Advaning's warranty provides coverage for all of its original Advaning Classic Series awnings that are sold and installed within the United States of America and Canada to be free of defects of materials and workmanship. This warranty only applies to the original owner/purchaser of the product and is only effective on a basis of thirty six (36) months or three (3) years from the date of purchase. Any defects or issues presented to Advaning within the warranty period will be promptly handled by Advaning customer service and resolved within a reasonable timeframe.

Entire awning framework, including extruded & die cast component parts, springs & cables are covered. Should the purchaser/original owner submit a warranty claim within the warranty period Advaning will provide a resolution option that may include; new replacement parts or instructions for repair or both. Powder coated and painted finishes are excluded and are NOT covered under this limited warranty.

During the warranty period, owners in Canada, Hawaii, Alaska and Puerto Rico are covered for parts/replacements at no charge, however, the owner would assume all shipping/handling and applicable duties and taxes. Advaning's Warranty does not cover any return shipping or prepaid return labels. Should the purchaser/owner notify Advaning within the warranty period from the date of the original purchase and after deemed defective by Advaning, will the warranty claim be resolved by either of the following: A. Defective component replacement (shipping charges may apply), B. Detailed instructions for correcting the issue, Or a combination of both A and B.

### **WARRANTY LIMITATION AND EXCLUSION**

The warranty will be in effect once the awning is fully paid for.

**Advaning** is not responsible for damages due to faulty modifications, installation, or re-installation.

Advaning assumes no liability for damage to the structure to which the awning is attached, or to the property located underneath the awning. This limited warranty does not cover damage from ice, snow, hail, high winds, vandalism, neglect, improper use, or any natural disasters. This limited warranty does not cover degradation due to salt corrosion, oxidation, and chipping or peeling of the paint.

### **Problems and Warranty Claims**

If you experience a problem with your Advaning product, please contact Advaning Customer Service at [service@advaning.com](mailto:service@advaning.com).

- Prior to contacting Advaning via phone or email for warranty claims, please have your model name/number, serial/lot number, original proof of purchase\*, and a description of difficulty experience ready for our Customer Service team. Most issues can be resolved over the telephone by our trained Customer Service representatives. If any issues arise that cannot be solved over the phone or email, Advaning will issue a Return Merchandise Authorization ("RMA") number, and arrange replacement parts for you.  
\*Proof of Purchase: A valid sales/purchase receipt is required with authorized reseller/retailer name, the purchase date and the model number of the item purchased.
- Submitting a claim will not extend or alter the warranty coverage period. Any work done by a 3rd party or non-authorized person/Advaning agent will void the warranty.

THIS WARRANTY IS EXCLUSIVE AND IS IN LIEU OF ANY AND ALL OTHER WARRANTIES, EXPRESSED OR IMPLIED. NO IMPLIED WARRANTIES OF MERCHANTABILITY OR FITNESS FOR A PARTICULAR PURPOSE

# WARRANTY AND CUSTOMER SERVICE

ARE GIVEN, ANY AND ALL LIABILITY FOR BREACH OF ANY IMPLIED WARRANTY OR WARRANTY CREATED BY LAW IS DISCLAIMED.

Some states do not allow limitations on how long an implied warranty lasts, so the above limitation may not apply to you.

UNDER NO CIRCUMSTANCES SHALL ADVANING, INCLUDING ITS SUBSIDIARIES AND AFFILIATES BE LIABLE FOR INCIDENTAL OR CONSEQUENTIAL DAMAGES WITH RESPECT TO ECONOMIC LOSS, INJURY, DEATH OR PROPERTY DAMAGE, WHETHER AS A RESULT OF BREACH OF THIS WARRANTY, NEGLIGENCE OR OTHERWISE.

Some states do not allow the exclusion or limitation of incidental or consequential damages, so the above limitation or exclusion may not apply to you in whole or in part. This warranty gives you specific legal rights. You may also have other rights that vary from state to state.

## **What is Not Covered by the Advaning Limited Warranty**

This warranty is non-transferable and does not cover product purchases from the initial buyer to a third party. This warranty does not cover incidental damages, such as loss of time, loss of use, or installation costs of defective, repaired or replaced product. This warranty does not cover product that has been damaged or rendered defective as a result of:

- (a) Neglect, abuse or misuse.
- (b) Modification of the original product.
- (c) Improper use or installation using products not manufactured by Advaning.
- (d) Service provided by anybody other than Advaning.
- (e) Abnormal mechanical or environmental conditions.
- (f) Unusual physical or electrical stress -including failure or fluctuation of electrical power, lighting, static electricity, fire, tornadoes, or other natural disasters.

## **Shipping Damage Claim:**

On the occasion of a damage claim caused by the shipper/shipping company, the owner must contact their point of sale and the delivering freight carrier within 3 days of signing for the delivery in order to make a claim. Failure to report freight damage and missing parts in a timely manner and in accordance to the carrier's guidelines may result in you incurring all costs. Likewise, there are 5 days from the time of delivery to report missing parts to Advaning.

For more information, please contact the corporate office.

Advaning Customer Service Center  
Email: [service@advaning.com](mailto:service@advaning.com)

## **LIMITED TIME OFFER – Free, 8 Months \*Extra Warranty Coverage**

Register your awning purchase within 60 days of purchase along with \*\*installation photos to receive an \*Extra 8 months of warranty coverage.

[www.advancing.com/warranty-registration](http://www.advancing.com/warranty-registration)

\*parts only, shipping not included. / \*\*submitting photos grants Advaning permission to reproduce any portion of the photo image for print, web, or any other marketing purpose including social media outlets.

## CONTACT INFORMATION

### Product Questions?

Please contact Advaning via email at [service@advaning.com](mailto:service@advaning.com), by phone at 714-622-2600, or by chat on our website; [www.advaning.com](http://www.advaning.com)

Advaning Customer Service is available Monday through Friday from 8:30 a.m. to 4:00 p.m. PST

[www.advaning.com](http://www.advaning.com)